

MICRO-IMAGECHECKER A200/A100

Hardware Manual

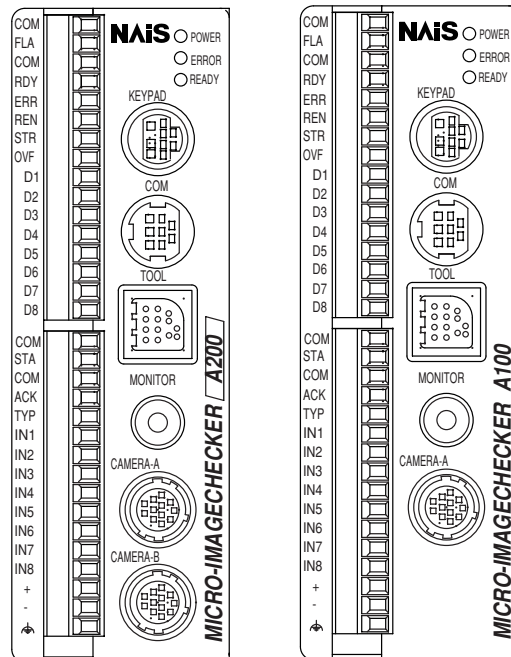

A200 Series

A100 Series



This manual was created using Adobe Acrobat. Adobe, the Adobe logo, and Acrobat are trademarks of Adobe Systems Incorporated.

Hardware Manual
ARCT1F326E-4 '04.02

WARNINGS AND CAUTIONS

To be observed at all times

Read the manual carefully before installing, running, maintaining or inspecting the equipment.

This manual uses two safety flags to indicate different levels of danger.

WARNING: A handling error could cause serious physical injury to an operator, and in the worst case could even be fatal.

CAUTION: A handling error could cause serious physical injury to an operator, or damage to the equipment.

WARNING

A handling error could cause serious physical injury to an operator, and in the worst case could even be fatal.

- When using the equipment for a purpose which could conceivably result in the physical injury of an operator and/or damage to the equipment itself, adequate secondary or backup safety and/or protection mechanisms of one sort or another should also be incorporated into the system.
- Do not use the Imagechecker in an environment which contains combustible gases as this may result in an explosion.
- Never open the Imagechecker. The main unit contains high-voltage components which are dangerous to touch. Do not loosen the retaining screws as this may result in electric shocks.

CAUTION

A handling error could cause serious physical injury to an operator, or damage to the equipment.

- Configure so that the emergency stop and interlock circuits are external circuits.
- Be certain to use the equipment within its specified ratings and environmental conditions at all times. Failure to do so can cause overheating.
- Do not disassemble or restructure the Imagechecker in any way as this may result in electric shocks or in the emission of smoke.
- Do not bend the controller's power cable, or place anything heavy on top of the cable. Do not allow the cable close to any other items of equipment that emit significant amounts of heat. When disconnecting the power cable, always grip the plug, and never pull the cable, as this could result in an electric shock or the emission of smoke.
- Always ground the earth wire. Failure to do so may result in an electric shock.
- The power cable must be carefully secured in position using the terminal screw. A faulty connection may result in the generation of excessive heat or the emission of smoke.
- Do not touch the terminals while the power is ON, as this may result in an electric shock.

GENERAL INSTRUCTIONS

Installation Environment

Avoid using the Micro-Imagechecker A210/A110 in the following types of locations:

- Locations with direct sunlight or environmental temperatures that exceed a range of 0 deg. to 50 deg..
- Locations with a relative humidity exceeding a range of 35%RH to 75%RH or that are subject to condensation due to dramatic temperature fluctuations.
- Locations with an atmosphere containing corrosive gases or flammable gases.
- Locations that subject the main unit to direct vibration or impact.
- Locations with a lot of fine particles, iron filings or salt.
- Locations likely to have contact with water, oil or chemicals.
- Locations with an atmosphere likely to contain organic solvents such as benzene, paint thinner, and alcohol as well as strongly alkaline materials such as ammonia and caustic soda.

Static Electricity

In a dry environment, there is a risk of accumulation of static electricity, so when there is a need to touch the equipment, users should always discharge the accumulated static by touching an earthed part of the equipment first.

Cleaning

Do not use thinners or similar solvents, as they may dissolve parts of the unit and cause colors to run.

Power

Use an insulated power source with built in protection circuits. The controller power unit uses non-insulated circuits, so if an irregular voltage is applied, there is a danger that the internal circuitry will be damaged. If you use a power source that does not use protection circuits, supply the power via a fuse or other protective device.

Power Sequence

- Arrange the power sequence so that the controller power source is turned off before the input/output power source.
- If you turn off the input/output power source before the controller power source, the controller unit will detect an input signal level change and may not run properly.

Before Switching On the Power

The following points should be checked before switching the power on to the controller for the first time.

- Check that no extra wiring left installation, especially conductive materials, have become attached to the board.
- Confirm that the power supply wiring and I/O wiring and power supply voltage are correct.
- Firmly tighten all installation screws and terminal block screws.

Before Creating Type Data

Before creating type data, be sure to initialize the environment settings and all type settings.

- ☛ See User's Manual for more information about initialization.

Other Instructions

- Use monitor, monitor cable, keypad, camera and camera cable models and serial numbers specified by Matsushita.
- Do not disassemble, modify, or change internal settings for the Micro-Imagechecker unit or other equipment.
- Setting or changing items other than those that can be set or changed, as described in the product manual and specifications, will result in damage.
- After completing all of the settings for the Micro-Imagechecker, do not connect the personal computer used for connecting the keypad, restoring or backup, in order to prevent malfunctioning due to noise.
- Do not perform insulation resistance or pressure resistance tests between metal areas of the power supply, input/output signal and connectors and the camera case.

To USA Customer

- Products sold by Seller are covered by the warranty and patent indemnification provisions in its Terms and Conditions of Sale only.

Contents

Chapter 1 Part Names and Functions

1.1	Controller	1 - 3
1.2	A Series Camera	1 - 5
1.2.1	Double-Speed Random Camera	1 - 5
1.2.2	CS-Mount Camera	1 - 7
1.3	Camera Cable and Camera Extension Cable	1 - 8
1.4	Keypad	1 - 9

Chapter 2 Installation and Wiring

2.1	Connecting Peripherals	2 - 3
2.2	Installation Environment and Mounting Space	2 - 4
2.3	Mounting the Controller	2 - 6
2.4	Mounting the Camera	2 - 7
2.5	View range and Lens Selection Tables	2 - 8
2.5.1	ANM831 Double-Speed Random Camera	2 - 8
2.5.2	ANM832 Standard Camera	2 - 9

Chapter 3 Input/Output Terminals (Input/Output Ports)

3.1	Attaching Wires to the Terminal Blocks	3 - 3
3.2	Output Terminal (Parallel Output Port)	3 - 4
3.3	Input Terminal (Parallel Input Port)	3 - 5
3.4	Cautions Related to Parallel Input/Output	3 - 6
3.4.1	About Parallel Output	3 - 6
3.4.2	About Parallel Input	3 - 7
3.5	Flash Output Sync Signal	3 - 8
3.6	Electric Power Wiring	3 - 10
3.7	About Grounding	3 - 12

Chapter 4 Serial (RS-232C) Ports

4.1	Serial (RS-232C) Ports	4 - 3
4.2	COM port (Data output, VBT Ver. 2)	4 - 5
4.3	TOOL port (VBT Ver. 2 Port)	4 - 10

Chapter 5 About Camera Modes

5.1	Camera Modes	5 - 3
5.2	Imaging Time for the Camera Modes (for memory image display) and Resolution	5 - 4
5.3	Frame Mode and Field Mode	5 - 5

Chapter 6 Product Type Data Creation and Backup

6.1	Product Type Data Creation and Backup	6 - 3
-----	---	-------

Chapter 7 General Specifications

7.1	Controller	7 - 3
7.2	Key pad	7 - 4
7.3	Monitor	7 - 5
7.4	Double-Speed Random Camera ANM831	7 - 6
7.5	CS-Mount Camera ANM832	7 - 7

Chapter 8 Part Numbers

8.1	Controllers	8 - 3
8.2	Cameras	8 - 5
8.3	Double-Speed Random Camera Cable	8 - 6
8.4	Camera Extension Cable	8 - 7
8.5	Keypad	8 - 8
8.6	Monitor	8 - 9
8.7	Data Backup Software and PC Cable	8 - 10
8.8	Lenses and Adapter Rings	8 - 11
8.9	Lighting for Image Processing	8 - 12

Chapter 9 Dimension diagramv

9.1	Controller	9 - 3
9.2	Camera	9 - 4
9.2.1	Double-Speed Random Camera ANM831	9 - 4
9.2.2	CS-Mount Camera ANM832	9 - 4
9.3	Camera Cable and Camera Extension Cable	9 - 5
9.4	Keypad	9 - 6
9.5	Monitor: ANMA810	9 - 7
9.6	Lenses	9 - 8

Chapter 10 Reference

10.1	Camera Pin Positions (ANM831)	10 - 3
10.2	Camera Pin Positions (ANM832)	10 - 4

Chapter 11 Manual revision history

11.1	Manual revision history	11 - 3
------	-------------------------------	--------

Chapter 1

Part Names and Functions

1.1	<i>Controller</i>	1 - 3
1.2	<i>A Series Camera</i>	1 - 5
1.2.1	<i>Double-Speed Random Camera</i>	1 - 5
1.2.2	<i>CS-Mount Camera</i>	1 - 7
1.3	<i>Camera Cable and Camera Extension Cable</i>	1 - 8
1.4	<i>Keypad</i>	1 - 9

1.1 Controller

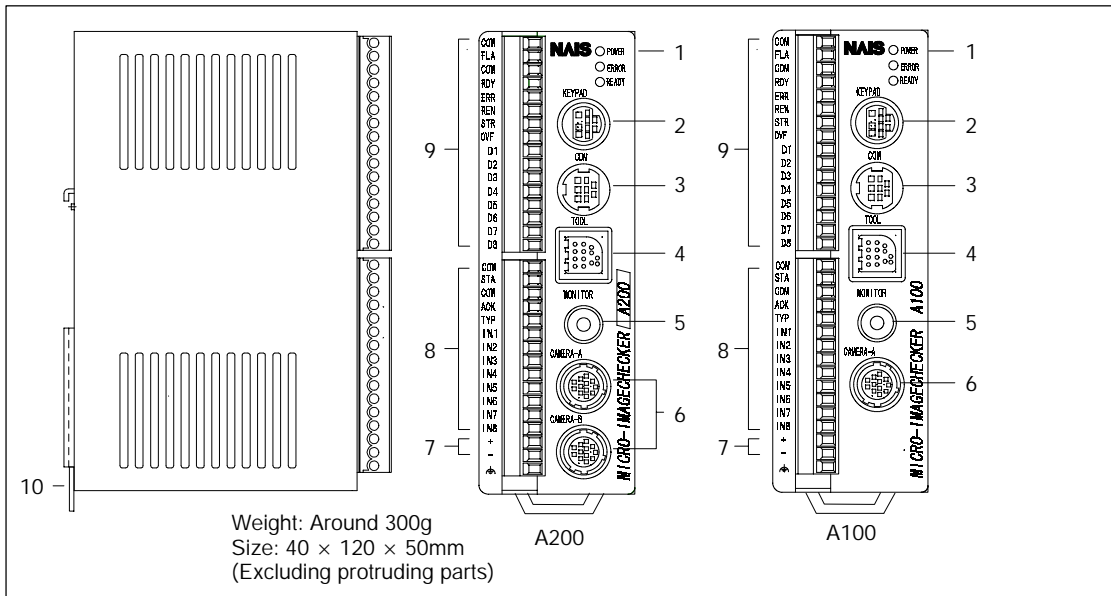

Names and Functions of Controller Parts

1. Operating LEDs
Indicate the controller's operating status.
POWER (green) This green LED is lit when the controller is connected to a live power source.
ERROR (red) The red LED is lit when an error has occurred.
READY (green) This green LED is lit when the start signal can be input. (when ready for inspection)
2. Keypad jack
Provides a connection for the operation keypad.
3. RS-232C port
Provides an RS-232C connection for an external device.
4. Tool port
Provides an RS-232C connection for an external device (only VBT Ver. 2).
5. Monitor
Provides a connection for a monitor.
6. Camera jack
One camera jack is provided on an A100.
Two camera jacks are provided on an A200, one for camera A and one for Camera B.

1.1 Controller

7. Power supply
24 power is required. The power supply is connected to the input terminal block.
8. External input terminal (16 pin)
Provides a connection for input from an external source.
9. External output terminal (16 pin)
Provides a connection for output to an external device.
The input/output terminal block is part order number 1840502 from Phoenix Contact. See page 3 - 3 for details about compatible electric wiring and the terminal block.
10. DIN rail mounting lever
You can mount the controller onto a DIN rail with one easy (one - two hook) motion.

Using the Controller Correctly

- When you connect multiple cameras to an A200 controller, be sure the cameras are of the same type.
- When you connect only one camera to an A200 controller, plug it into the Camera A jack.
- Do not connect any products to the controller other than those specified by us.

1.2 A Series Camera

1.2.1 Double-Speed Random Camera

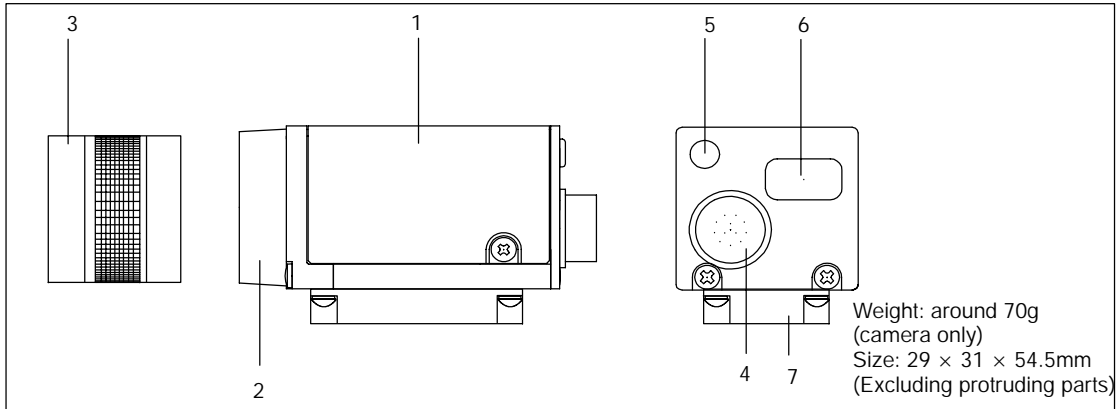

Names and Functions of Double-Speed Random Camera Parts

1. Camera
The camera body.
2. Lens mount
A C-mount.
3. Lens
If a C-mount is required for your application, mount it using an extension ring. Select a lens from the Field of Vision and Lens Selection Table on page 2 - 8.
4. Cable connector
The camera is connected to the controller with a camera cable having the specified part number.
5. Gain fine turning knob
Used to finely adjust the camera gain.
6. DIP-SW
Switches camera modes between frame and field, adjusts camera gain.
7. Mounting hardware
Hardware used to mount the camera.

1.2 A Series Camera

About the DIP Switches

- Gain adjustment
DIP switch 5: ON = 0 to +10dB range gain adjustment volume.
OFF = 0dB
- Potentiometer: When DIP-SW5 is ON, turning this potentiometer to the right increases the brightness of the image captured by the camera.
- Camera mode switch
DIP switch 6: ON = frame mode
OFF = field mode
- Other
DIP switches 1 to 4, 7, 8: Normally OFF
- Settings when shipped
DIP switch 5 = ON, VOL +10dB. All others are OFF.

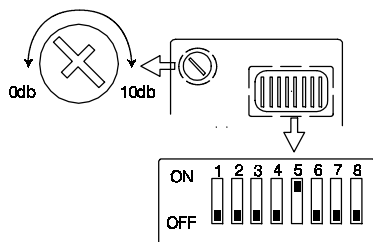
**Using the Camera Correctly**

- When you connect more than one camera to an A200 controller, be sure the cameras are of the same type.
- When you connect only one camera to an A200 controller, plug it into the Camera A jack.
- Do not use products other than those specified by us for camera cables or camera extension cables.
- Do not connect multiple camera cables or camera extension cables to one another to make an extension.
- Do not touch the camera's CCD elements or lens surface. Also, be sure to cap the camera when storing it in order to prevent smudges on the CCD elements or lens surface.
- Change the DIP switch positions in accordance with the camera mode.
- Be very certain not to change the DIP switch settings of other DIP switches.

1.2.2 CS-Mount Camera

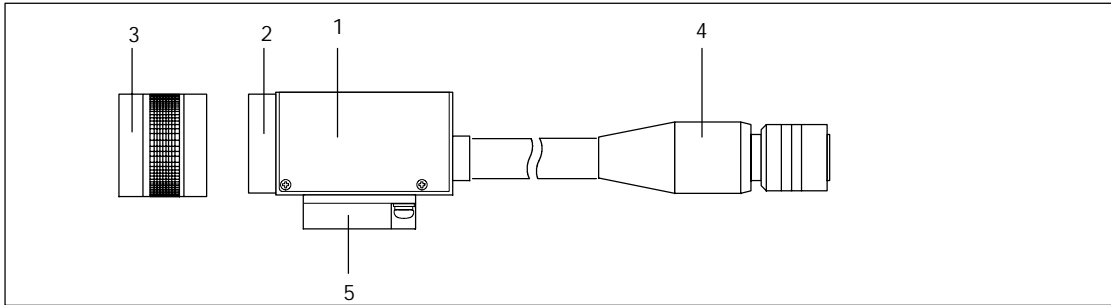

CS-Mount Camera: Part Names and Functions

1. Camera
The camera's main unit.
2. Lens mount
A CS-mount.
3. Lens
If a C-mount or CS-mount lens is required for your application, mount it using a extension ring. Select a lens from the Field of Vision and Lens Selection Table on page 2 - 9.
4. Cable connector
The camera is connected to the controller via this connector. If necessary, also use a camera extension cable with a part number specified by us.
5. Mounting hardware
Hardware used to mount the camera.

Using the Camera Correctly

- When you connect multiple cameras to an A200 controller, be sure the cameras are of the same type.
- When you connect only one camera to an A200 controller, plug it into the Camera A jack.
- Do not use products other than those specified by us for camera cables or camera extension cables.
- Do not connect multiple camera cables or camera extension cables to one another to make an extension.
- Do not touch the camera's CCD elements or lens surface. Also, be sure to cap the camera when storing it in order to prevent smudges on the CCD elements or lens surface.

1.3 Camera Cable and Camera Extension Cable

1.3 Camera Cable and Camera Extension Cable

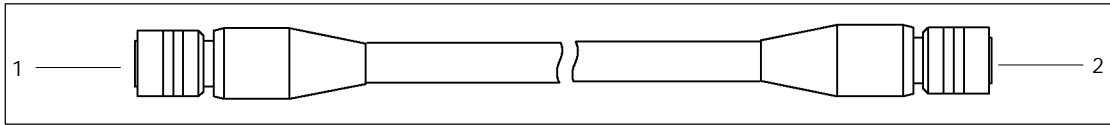

Names and Functions of Parts

1. Connector (male):
Connects the male connector to the controller.
2. Connector (female):
Connects the female connector to the camera.

Using the Cable Correctly

- Do not use products other than those specified by us for camera cables or camera extension cables.
- Do not connect multiple camera cables or camera extension cables to one another to make an extension.
- Do not bend camera cables unnecessarily or place loads on the connector joints.

1.4 Keypad

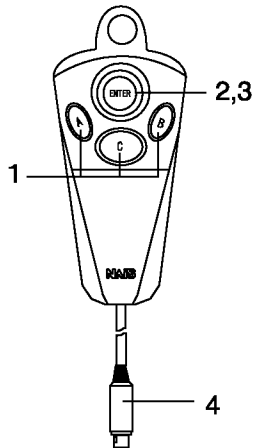

Names and Functions of Parts

1. A, B, C buttons
Can be operated using function displayed on the screen.
2. Cursor lever
Moves the cursor. Can move it in a maximum of eight directions.
3. Enter button
Confirms an entry.
4. Terminal
Connects the keypad to the A Series controller.

Operation of the Cursor lever and ENTER button

When you press the cursor lever to move the cursor an ENTER may be input erroneously. To avoid this problem, remove your finger from the cursor lever momentarily as you change cursor movement direction.

- The functions available from the keypad depend on the functions provided by the controller.

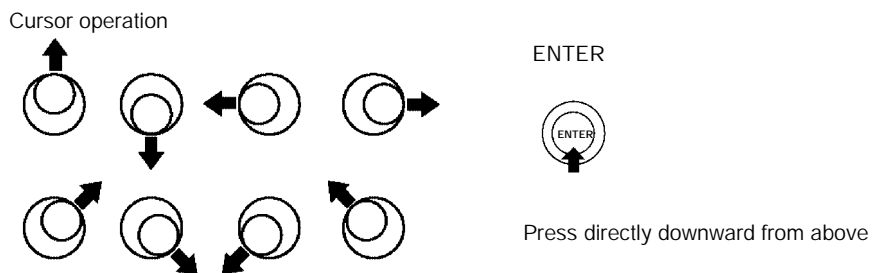

Using the Keypad Correctly

- Avoid connecting a keypad not specified by us to the controller.

1.4 Keypad

Chapter 2

Installation and Wiring

2.1	<i>Connecting Peripherals</i>	2- 3
2.2	<i>Installation Environment and Mounting Space</i>	2- 4
2.3	<i>Mounting the Controller</i>	2- 6
2.4	<i>Mounting the Camera</i>	2- 7
2.5	<i>View range and Lens Selection Tables</i>	2- 8
2.5.1	<i>ANM831 Double-Speed Random Camera</i>	2- 8
2.5.2	<i>ANM832 Standard Camera</i>	2- 9

2.1 Connecting Peripherals

Be sure to connect peripherals to the controller only when the controller power is OFF.

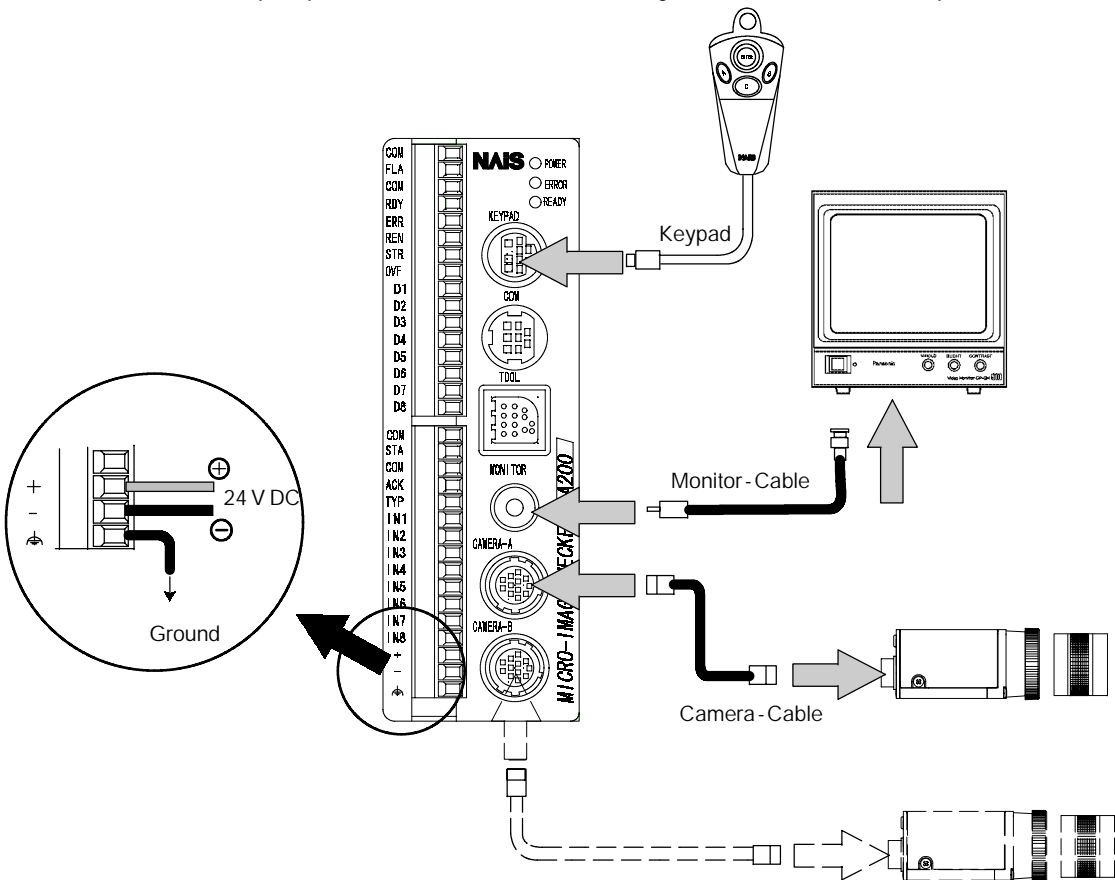

*Only one camera can be connected to the A100.

Using Peripherals Correctly

- Do not connect products not specified by us to the controller.
- Be sure to connect peripherals only when the controller power is turned OFF. Otherwise, damage could result.
- When you connect multiple cameras to an A200 controller be sure the cameras are of the same type.
- When you connect only one camera to an A200 controller plug it in to the Camera A jack.
- Avoid unintentional cable detachment by arranging the wiring so there is no weight or load on the cable connector joints.
- When unplugging a connector, be sure to grasp the connector part itself and avoid exerting unnecessary force on the cable. Also, avoid touching or allowing water to come in contact with the connector pins.

2.2 Installation Environment and Mounting Space

Avoid Installing the Equipment in Locations with the Following Characteristics

- Where the temperature is outside the range of 0 deg. to 50 deg..
- Where the relative humidity is outside the range of 35%RH to 75%RH.
- Where there is a danger of condensation due to sudden temperature fluctuations.
- In the presence of corrosive gas or combustible gas.
- Where dust, metal powders, or salt are present in large amounts.
- In an environment where there is a possibility that organic solvents such as benzene, paint thinner, or alcohol, or strong alkaline substances such as ammonia or caustic soda may adhere.
- Where the equipment will be subject to vibration or shock.
- In direct sunlight.
- Where there is a possibility that water, oil, or chemicals may come into direct contact.
- Where there will be a weight load placed on the main unit.

Noise Considerations

- Install the unit as far away as possible from high-voltage lines and equipment, drive lines and equipment, and other equipment that may generate large power surges when it turns on or off.
- Install the unit as far away as possible from equipment such as amateur radio transmitters.

Heat Dissipation

- Mount the unit in any of the following arrangements to facilitate heat dissipation.

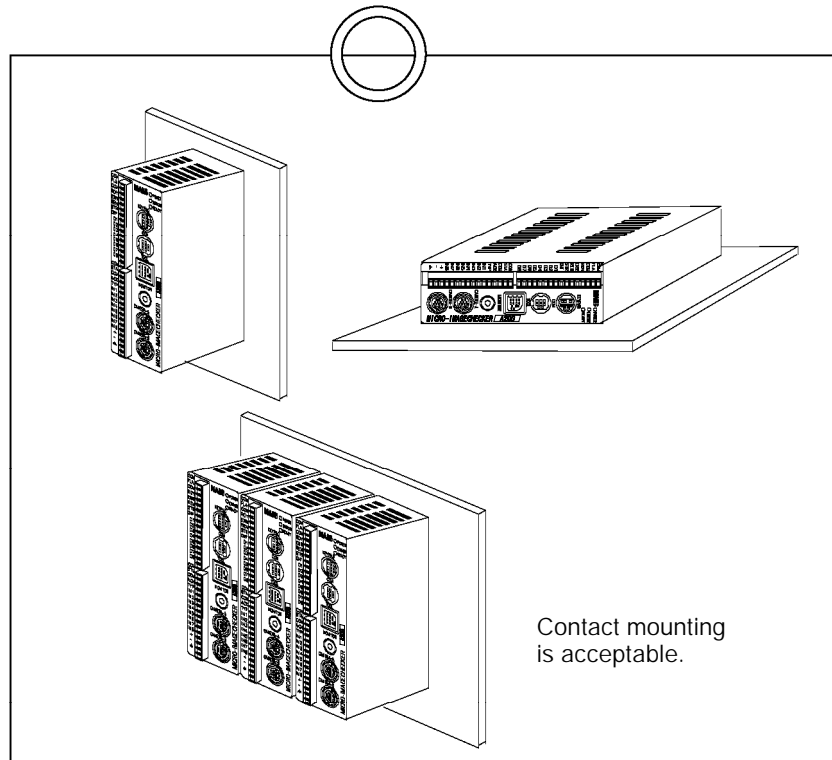

Do not mount the unit on top of strong heat sources such as heaters, transformers, or high-capacity resistors.

About Mounting Space

- When installing the unit, aim to leave at least 50mm between the controller and any nearby objects such as ducts or other equipment. Controller replacement and wiring will be easier this way.
- When you install doors or other equipment in front of the controller's front panel provide at least a 100mm space between the controller and the equipment in order to avoid noise and heat effects.
- Provide at least 100mm of space in front of the controller's front panel to provide for the keypad connection and wiring.

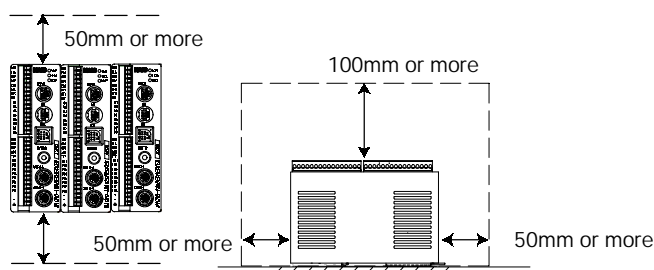

2.3 Mounting the Controller

2.3 Mounting the Controller

You can mount the controller either by using screws or by hooking it on a DIN rail.

Mounting the Controller on a DIN Rail

The controller can be mounted on or removed from a 35mm wide DIN rail (DIN EN50022) by a single easy motion.

Mounting

1. Catch the controller on to the hook rail at the top of the DIN rail.
2. Press the controller into position.

Removing

1. Push a straight screwdriver into the mounting lever.
2. Press the mounting lever downward.
3. Pick up the controller to remove it.

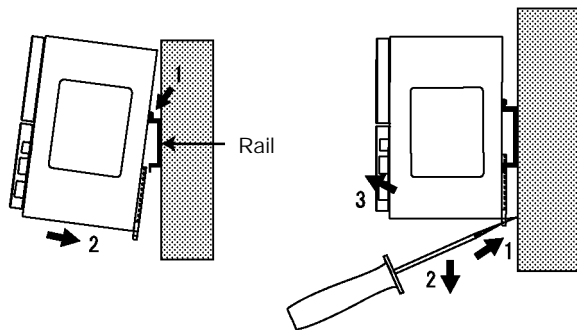

Mounting the Controller Using Screws

Refer to the dimension diagrams on page 9-3, and secure the controller using M3 screws.

2.4 Mounting the Camera

Mount the camera so it doesn't wobble. You can mount the camera directly or with hardware. Use the dimensional diagram for reference when you mount the camera.

Using the Camera Correctly

- Connect the camera case to the internal circuit ground. When you mounted the camera to a device with a different electric potential there is a concern that internal damage could result, so mount it in an electrically isolated way.
- In order to eliminate the effect of within-tolerance variations of CCD mounting dimensions when the camera is mounted, be sure to verify it with an actual image.

2.5 View range and Lens Selection Tables

2.5 View range and Lens Selection Tables

Select the lens and extension rings from the following table in order to match the resolution or view range.

2.5.1 ANM831 Double-Speed Random Camera

Lens		ANM8850 f=50mm		ANB847 f=50mm		ANB846N ANM88251 f=25mm		ANB845N ANM88161 ^(*) f=16mm		ANB843 f=8.5mm		ANB842 f=6.5mm		Resolution µm/pixel		
View range (mm)	Vertical view range	Horizontal view range	al		bα		al		bα		al		bα		Vertical	Horizontal
			1	1.1	59	178	48	178								
2	2.1	73	89	62	89									4.2	4.2	
3	3.2	87	59	76	59									6.3	6.2	
4	4.3	101	44	90	44									8.3	8.3	
5	5.3	115	36	104	36	31	18							10	10	
7.5	8.0	150	24	139	24	49	12							16	16	
10	10.7	186	18	175	18	66	9	31	6					21	21	
12.5	13.3	221	14	210	14	84	7	42	5					26	26	
15	16.0	256	12	245	12	101	6							31	31	
20	21.3	326	9	315	9	137	2 ³	76	2 ²	30	1.5			42	42	
30	32.0	467	6	456	6	207	2 ²	121	2	54	1	42	1.0	63	62	
40	42.6					277	2	166	1	78	1	60	0.5	83	83	
50	53.3					348	2	211	1	102	0.5	79	0.5	104	104	
75	79.9					524	1	323	1	162	0	124	0	156	156	
100	106.5					700	1	436	0.5	221	0	170	0	208	208	
150	159.8							661	0	341	0	262	0	313	312	
200	213.1									461	0	353	0	417	416	
250	266.3									580	0	445	0	521	520	
300	319.6											536	0	625	624	

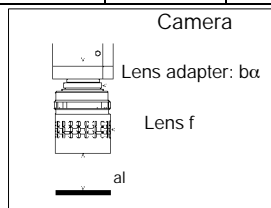

al : distance from end of lens to subject.
 $b\alpha$: thickness of lens adapter

Note

The view range - lens table is designed primarily for use as a focusing guide. Use the camera itself to make the final adjustments to focus, view range, distance to work, resolution and any other settings which need to be made before running the system.

Unless otherwise noted, the focus values in the chart are all infinity.

*1: $al = +4mm$

*2: Lens focal position is near middle.

*3: Lens focal position is in closest position.

2.5.2 ANM832 Standard Camera

View range (mm)		Lens		ANM8850 f=50mm		ANB847 f=50mm		ANB846N ANM88251 f=25mm		ANB845N ANM88161 ^(*) f=16mm		ANB843 f=8.5mm		Resolution μm/pixel	
		Vertical view range	Horizontal view range	a _l	b _α	a _l	b _α	a _l	b _α	a _l	b _α	a _l	b _α	Vertical	Horizontal
1	1.1	59	183	48	183								2.1	2.1	
2	2.1	73	94	62	94								4.2	4.2	
3	3.2	87	64	76	64								6.3	6.3	
4	4.3	101	49	90	49								8.3	8.3	
5	5.3	115	41	104	41	31	23						10.4	10.4	
7.5	8.0	150	29	139	29	49	17						15.6	15.6	
10	10.7	186	23	175	23	66	14	31	11				20.8	20.9	
12.5	13.3	221	19	210	19	84	12	42	10				26.0	26.1	
15	16.0	256	17	245	17	101	11	53	9				31.3	31.3	
20	21.4	326	14	315	14	137	9	76	8	30	6.5		41.7	41.7	
30	32.0	467	11	456	11	207	8	121	7	54	6		62.5	62.6	
40	42.7	608	9	597	9	277	7	166	6.5	78	5.5		83.3	83.4	
50	53.4					348	6.5	211	6	102	5.5		104.2	104.3	
75	80.1					524	6	323	5.5	162	5.5		156.3	156.4	
100	106.8					700	6	436	5.5	221	5.5		208.3	208.6	
150	160.2							661	5.5	341	5		312.5	312.9	
200	213.6							886	5	461	5		416.7	417.2	
250	267.0									580	5		520.8	521.5	
300	320.4												625.0	625.8	

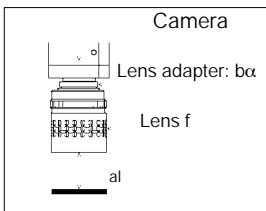

a_l: distance from end of lens to subject.
b_α: thickness of lens adapter

Note

The view range - lens table is designed primarily for use as a focusing guide. Use the camera itself to make the final adjustments to focus, view range, distance to work, resolution and any other settings which need to be made before running the system.

Unless otherwise noted, the focus values in the chart are all infinity.

*1: a_l = +4mm

2.5 View range and Lens Selection Tables

Lens View range (mm)		ANB842 f=6.5mm		ANM8808 f=8mm		ANM8804 f=4mm		ANM8828 f=2.8mm		Resolution µm/pixel	
Vertical view range	Horizontal view range	al	bα	al	bα	al	bα	al	bα	Vertical	Horizontal
1	1.1									2.1	2.1
2	2.1									4.2	4.2
3	3.2									6.3	6.3
4	4.3									8.3	8.3
5	5.3									10.4	10.4
7.5	8.0									15.6	15.6
10	10.7									20.8	20.9
12.5	13.3									26.0	26.1
15	16.0									31.3	31.3
20	21.4			31	1.5					41.7	41.7
30	32.0	42	5.5	54	1					62.5	62.6
40	42.7	60	5.5	76	0.5	33	0.5			83.3	83.4
50	53.4	79	5.5	99	0.5	44	0			104.2	104.3
75	80.1	124	5.5	155	0.5	73	0	45	0	156.3	156.4
100	106.8	170	5	211	0	101	0	64	0	208.3	208.6
150	160.2	262	5	324	0	157	0	104	0	312.5	312.9
200	213.6	353	5	437	0	213	0	143	0	416.7	417.2
250	267.0	445	5	549	0	270	0	183	0	520.8	521.5
300	320.4	536	5	662	0	326	0	222	0	625.0	625.8

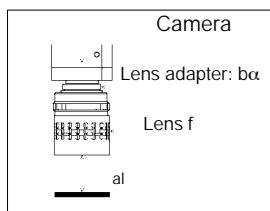

al: distance from end of lens to subject.
 bα: thickness of lens adapter

Note

The view range - lens table is designed primarily for use as a focusing guide. Use the camera itself to make the final adjustments to focus, view range, distance to work, resolution and any other settings which need to be made before running the system.

Unless otherwise noted, the focus values in the chart are all infinity.

Chapter 3

Input/Output Terminals (Input/Output Ports)

3.1	<i>Attaching Wires to the Terminal Blocks</i>	3 - 3
3.2	<i>Output Terminal (Parallel Output Port)</i>	3 - 4
3.3	<i>Input Terminal (Parallel Input Port)</i>	3 - 5
3.4	<i>Cautions Related to Parallel Input/Output</i>	3 - 6
3.4.1	<i>About Parallel Output</i>	3 - 6
3.4.2	<i>About Parallel Input</i>	3 - 7
3.5	<i>Flash Output Sync Signal</i>	3 - 8
3.6	<i>Electric Power Wiring</i>	3 - 10
3.7	<i>About Grounding</i>	3 - 12

3.1 Attaching Wires to the Terminal Blocks

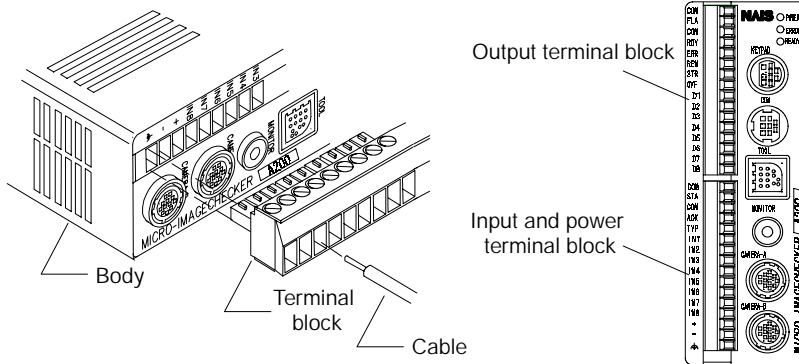

About Terminal Blocks

The I/O terminal block (Matsushita Denkou part number: ANMA8001, Phoenix part number: 1840502) plugs into the controller, and the terminals are fastened by tightening the screws.

Use the fittings and cable listed in the tables below.

Terminal block socket	Manufacturer		Part contact model number	
	Matusita Electric Works, Ltd.	ANMA8001		
	Phoenix Contact KK	Model number	Part order number	
		MC1.5/16-ST-3.5	1840502	

Screw-on fittings	Manufacturer	Conductor surface area (cross-section)	Conductor surface area (cross-section)	Screw torque
	Phoenix Contact KK	SZS0.4 × 2.5	0.4 × 2.5mm ²	0.25N . m or less

Socket for attaching terminal block	Size	Conductor surface area (cross-section)
	AWG#24 to 16	0.3 to 1.25mm ²

Wiring Method

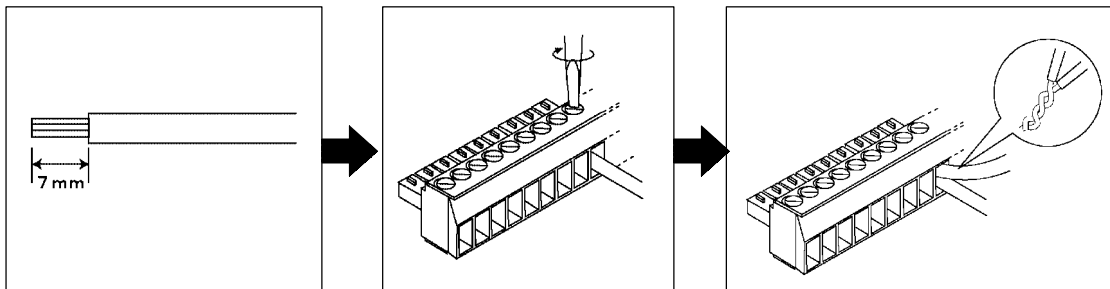

1. Remove the wire shield.
2. Insert the wire into a terminal block hole until it stops. Turn the screw.
3. When connecting two or more wires, twist them together before inserting.

Using Terminal Blocks Correctly

- Attach wires and attach or remove the terminal block only when the power is OFF.
- Do not use soldered wires. Vibrations may cause breakage.

3.2 Output Terminal (Parallel Output Port)

3.2 Output Terminal (Parallel Output Port)

Terminal Positions

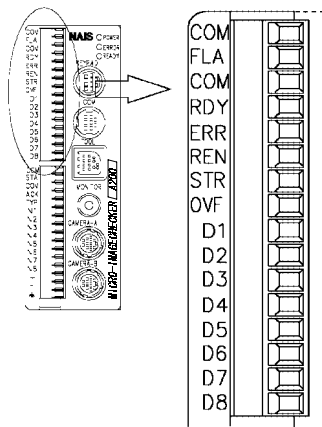

Signal	Name	Content
COM	COMMON	Common flash dedicated line
FLA	FLASH	Flash sync signal
COM	COMMON	General output common
RDY	READY	Ready signal
ERR	ERROR	Error signal
REN	READ END	Image capture complete signal
STR	STROB	Strobe signal
OVF	OVER FLOW FLAG	Overflow flag
D1	Data1	Data output signals D1 to D8
D2	Data2	
D3	Data3	
D4	Data4	
D5	Data5	
D6	Data6	
D7	Data7	
D8	Data8	

Output Circuit

Controller parallel output (NPN specification) circuit

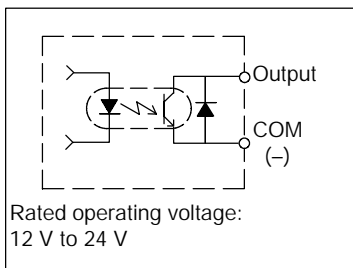

NPN controller output connection example

Example of connection with PLC
External power supply

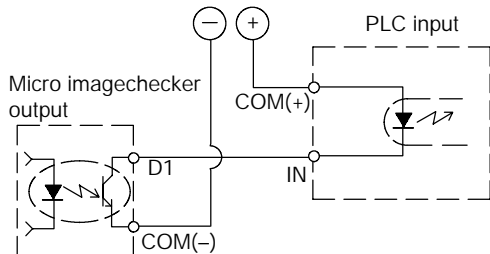

Photo-mos controller output circuit

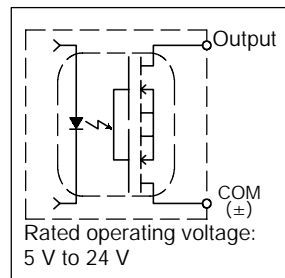

Photo-mos controller output connection example

Example of connection with PLC (Used as NPN)
External power supply

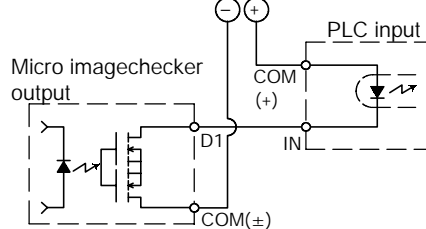
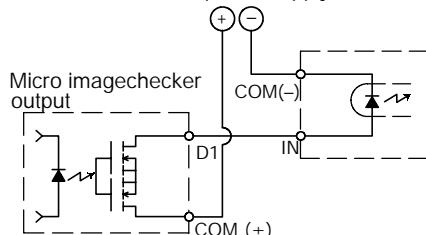

Photo-mos controller output connection example

Example of connection with PLC (Used as PNP)
External power supply



3.3 Input Terminal (Parallel Input Port)

Terminal Positions

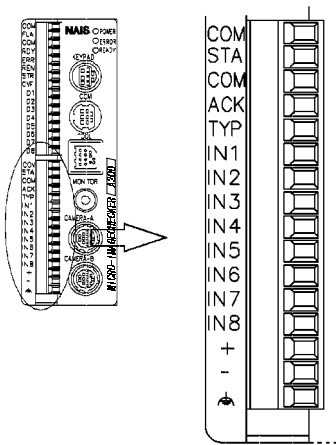

Signal	Name	Content
COM	COMMON	START common
STA	START	Inspection start signal
COM	COMMON	COMMON, other than START input
ACK	ACKNOWLEDGE	Data receiving complete signal
TYP	TYPE	Product type switched signal
IN1	IN1	Data input IN1 to IN8
IN2	IN2	
IN3	IN3	
IN4	IN4	
IN5	IN5	
IN6	IN6	
IN7	IN7	
IN8	IN8	
+	+24 V DC	Controller power supply = 24 V DC
-	-24 V DC	
	FUNCTIONAL EARTH	Functional ground

Input Circuit

Controller parallel input circuit

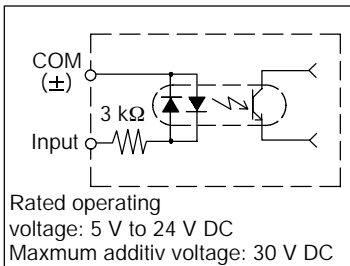

Example of connection with PLC used as NPN External power supply

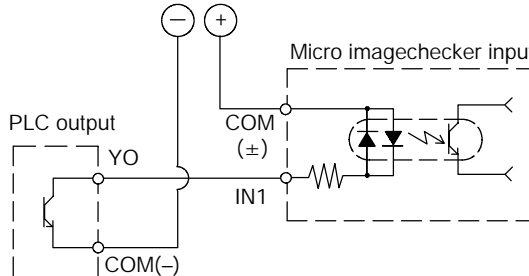

Example of connection with PLC used as PNP External power supply

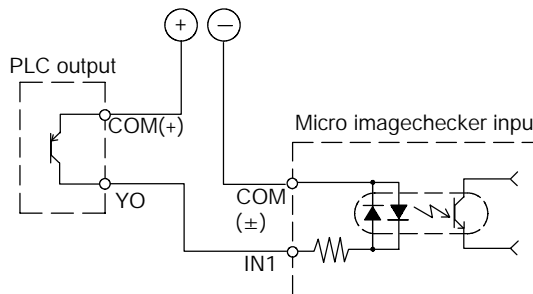

3.4 Cautions Related to Parallel Input/Output

3.4 Cautions Related to Parallel Input/Output

The input/output ports are housed in the particular controller being used. The ports differ according to the inspection specifications. See the individual controller's user manual for details.

3.4.1 About Parallel Output

- Depending on the controller being used, the output is either NPN open collector, or Photo-MOS. Be certain to use them within their rated load current range.
- The Photo-MOS output can be used as either PNP output or NPN output, but when connecting, make them uniform for the controller.
- The controller has only a low capacity to carry current. It takes into consideration connections with a PLC, etc., as shown above. Do not connect to a heavy load such as a directly-connected bulb. When such a requirement exists, pass it through our Power-Photo relay.
- The output load should be within the range specified below (Maximum 24mA per 1 Signal).

NPN output specification (external supply voltage: 12 V to 24 V DC)

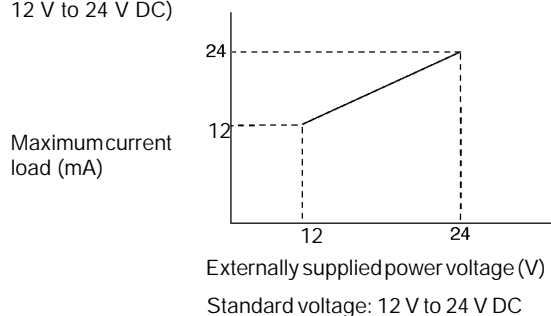
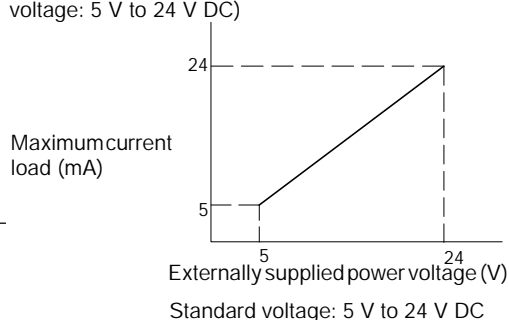

Photo-Mos output specification (external supply voltage: 5 V to 24 V DC)



- The output circuit contains no internal fuse. When it is necessary to prevent output circuit burnout in the event of an output load short circuit, attach an external fuse. However, there are cases when internal elements cannot be protected in the event of a short circuit.
- The common flash line has a specialized terminal. Do not use it together with other common lines.

3.4.2 About Parallel Input

- The controller accepts (\pm) common. To prevent input signal chattering, use a non-contact input (transistor etc.). If chattering occurs, inputs can be missed, and input recognition delayed.
- Be careful when using only full-wave rectification (including ripples) power supply for DC input, as it may cause abnormal operation.
- When current is leaking from the input side there are cases when input will not turn OFF. Use the diagram below as reference to connect resistance.

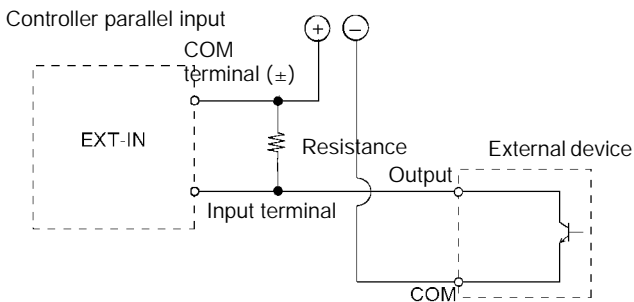

- When you are using a two-line opto-electrical sensor or proximity sensor and the controller will not turn OFF due to the effects of leaking electrical current, connect bleeder resistance.
- Even in cases where LEDs such as LED read switches are connected in series to an input contact point, make sure the controller's input terminal receives more voltage than the ON voltage.

3.5 Flash Output Sync Signal

3.5 Flash Output Sync Signal

Terminal Positions

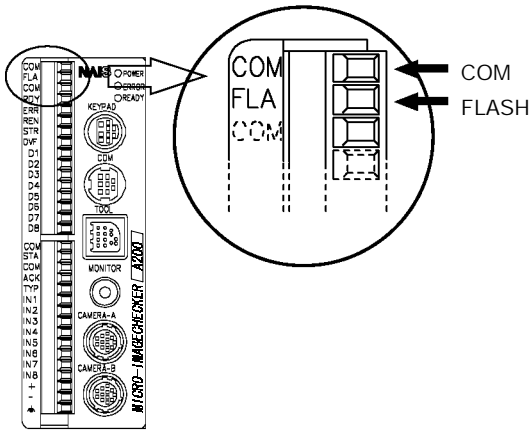

COM: The flash terminal is located in the output terminal.

FLASH: The common terminal for use by the flash is a specialized terminal. Do not use it together with other common lines.

Output Circuit

Use the output controller parallel output (NPN specification) circuit within the ranges illustrated below. (Maximum 24mA for 1 Signal)

NPN output controller output circuit

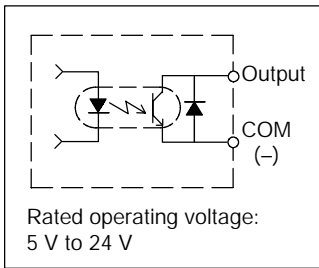
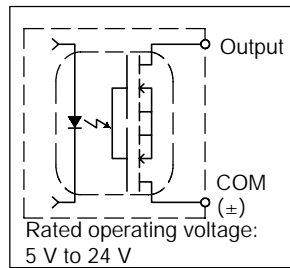
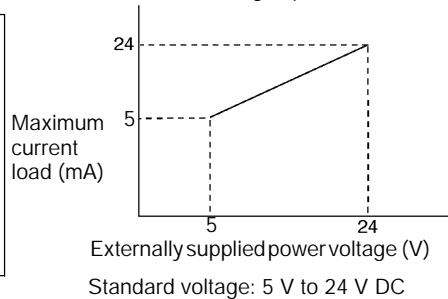

Photo-mos controller output circuit



Use within the range specified below



Flash Timing Chart

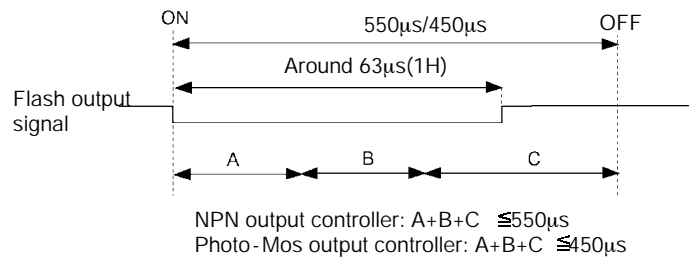

- A: Imagechecker flash output sync signal lag. This value changes depending on what type of strobe is attached.
- B: Strobe response time. Determined by the strobe.
- C: Strobe flash time. Determined by the strobe.

In the case on the NPN output controller, use a flash for which the time from when the flash output synchronization signal goes on to when the light generation finishes is 550µs or less. For the Photo-MOS controller, use a flash for which this time is 450µs or less.

A strobe can only be used for the flash output for the ANM830A camera in frame mode.

Using the Flash Output Sync Signal Correctly

- The flash's common wire uses a specialized terminal. Do not use it together with another common wire.
- You cannot use the same strobe for multiple cameras connected to separate controllers.
- When a strobe is used, the strobe flashes continuously during through screen display. Therefore, change to memory image display when connecting, setting up, and testing a strobe.

3.6 Electric Power Wiring

3.6 Electric Power Wiring

Terminal Positions

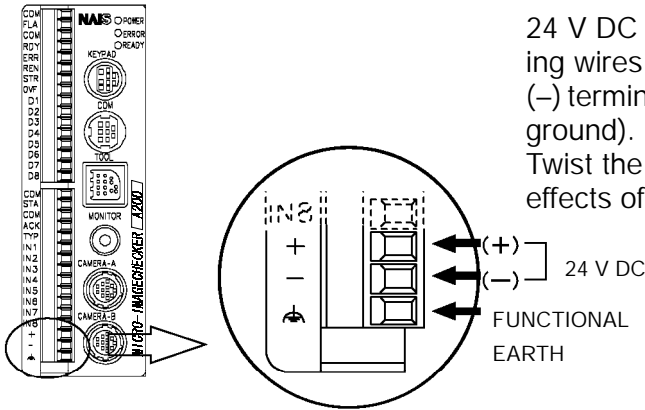

Standard voltage	24 V DC
Permitted voltage fluctuation range	21.6 V to 26.4 V DC
Standard current consumption	1 camera = 0.7A 2 cameras = 0.9A

Use a Power Supply with an Isolating Internal Protection Circuit

- Use an isolating power supply that incorporates an internal protection circuit in order to protect against abnormal voltages coming from the electric lines.
- The controller regulator is non-isolated.
- When using an electrical device that does not have an internal protective circuit be sure to supply electric power to the controller only after passing it through a fuse or other protective element.

Switch the power on and off at the primary side.

- Switch the power on and off at the primary side (100 V AC). If you switch the power on and off at the secondary side (24 V DC), you can cause the fuses to blow.

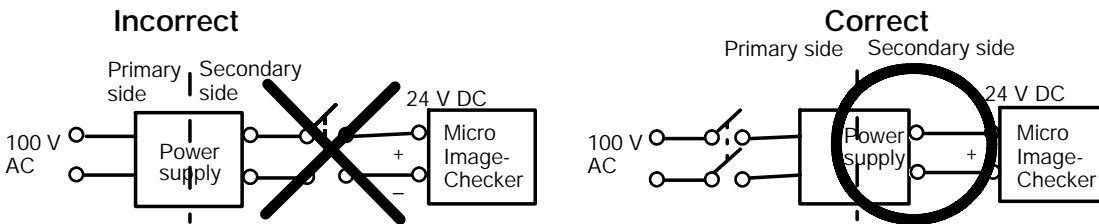

Use a power supply that has sufficient surplus capacity!

- When you first switch the power on, the temporary in-rush current far exceeds the rated current. Therefore, be certain to use a power supply that has sufficient surplus capacity to handle this (i.e. rated at about three times the steady-state current), and test it to ensure that it operates correctly.

Increase Resistance to Noise

- Separate the systems for wiring to the controller, input devices, and output devices.
- When there is a particular concern about noise coming from input/output circuits, supply power to the controller and to the input/output devices separately.

Consider the Electric Power Sequence

- Consider the electric power off sequence so the controller power is turned OFF before the input/output device power is turned OFF.
- If you turn OFF the input/output power before the controller power the controller main unit will detect a change in the input signal level and may operate abnormally.
- When you turn OFF the controller power wait at least 10 seconds before turning it ON again.

About Momentary Power Interruptions

10ms or less: Continues running

Between 10 and 20ms: Depending on the conditions, the system may continue running, the system may reset itself, or the camera image capture may stop.

20ms or more: The system will reset itself. When power is restored the system will begin operating from its initial state.

Using Electric Wiring Correctly

- Be sure to turn the power OFF before doing any electrical wiring.

3.7 About Grounding

Attaching a Ground to Prevent Effects of Noise

- The controller can tolerate the noise present in a normal environment. Provide a ground when installing it in a particularly noisy environment.

Use a Dedicated Ground Wire

- Use a third-type ground of 0.3 to 1.25mm² or more and with ground resistance of 100Ω or less.
- Locate the ground as close as possible to the controller and minimize the length of the ground wire.
- Use a dedicated ground wire in order to avoid negative effects from ground wires shared with other devices.

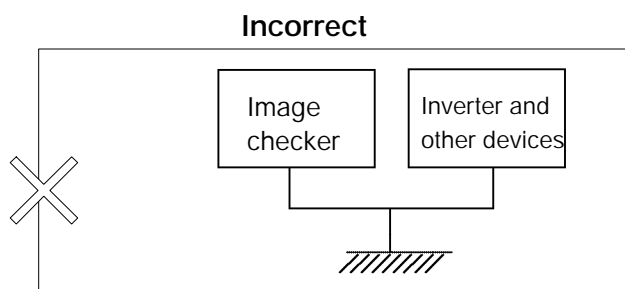
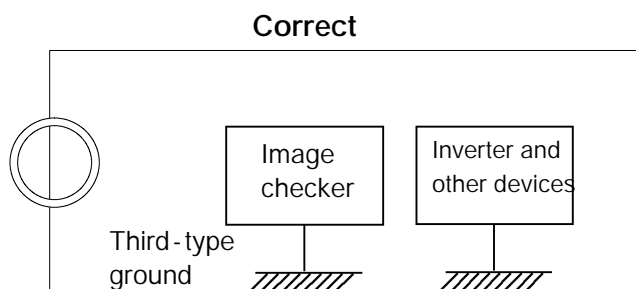

Chapter 4

Serial (RS-232C) Ports

4.1	<i>Serial (RS-232C) Ports</i>	4- 3
4.2	<i>COM port (Data output, VBT Ver. 2)</i>	4- 5
4.3	<i>TOOL port (VBT Ver. 2 Port)</i>	4- 10

4.1 Serial (RS-232C) Ports

The controller contains two independent serial ports.

The COM port is an 8-pin round connector. It is used for general RS-232C communication.

The TOOL port is a square connector. It is used only for connection to VBT Ver. 2.

An application stored in the controller determines the commands and parameters such as baud rate and parity used for communication. For details see each individual user manual.

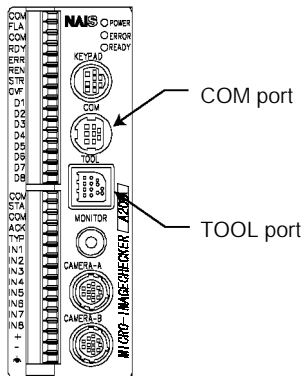

Using the Ports Correctly

- The A Series can be set to perform flow control of RS-232C communications. (For details, see the individual manuals.)
- There may be cases where normal communications are not possible with the high-speed transmission speed setting owing to the type of the equipment used for communications. Ensure that the conditions of actual usage are verified prior to operations.

4.1 Serial (RS-232C) Ports

Examples of RS-232C Connections

General-purpose RS-232C and VBT Ver. 2 can be used for the COM port.
Only VBT Ver. 2 can be used for the TOOL port.

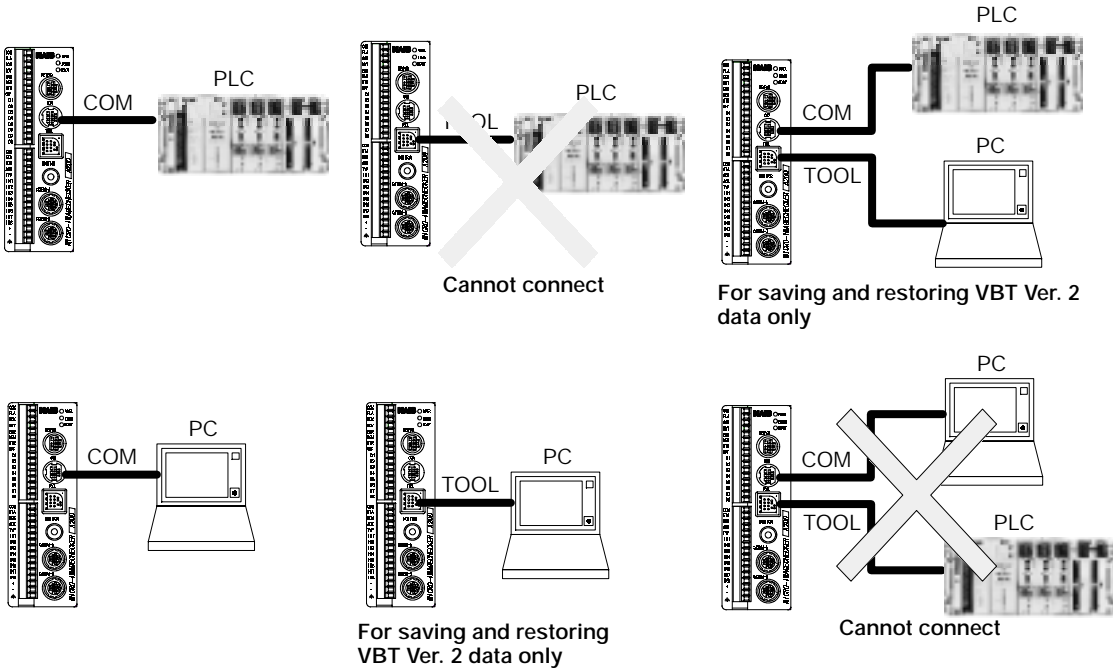

PLC
Inspection results and measured data from the A Series is communicated to the PLC. The PLC controls machinery systems.

PC
A specialized software program running under Windows is used to backup and restore image data and various types of setting data stored in the A Series controller.

4.2 COM port (Data output, VBT Ver. 2)

Terminal Positions

A Hoshiden-manufactured connector (part no. TCS6180) is used as the COM (RS-232C) port on the controller unit.

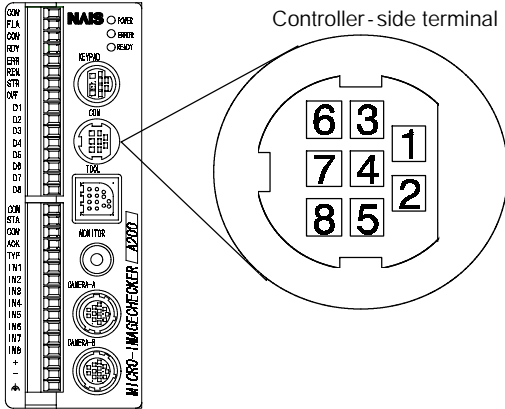

Pin No.	Wire color	Signal Name
1	Red	TxD
2	White	RxD
3	Black	RTS
4	Yellow	CTS
5	Blue	DSR
6	Green	GND
7	Brown	DCD
8	Gray	DTR

Example wiring

- IBM: Connection with an IBM PC -AT compatible
PC-AT Compatible Machine

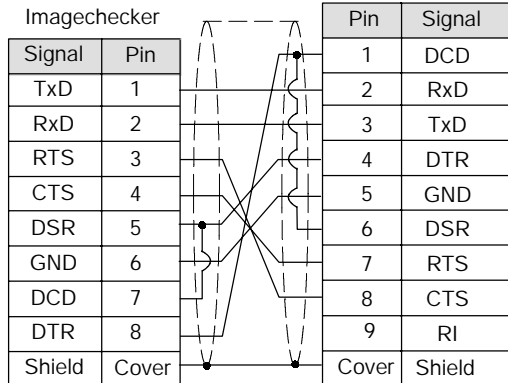

Please use the ANM81103 RS-232C cable provided.
(You do not need to prepare anything.)

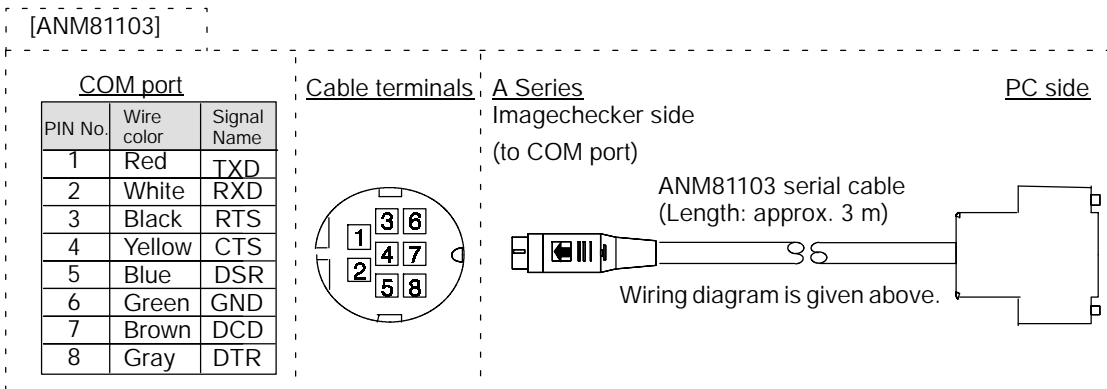

4.2 COM port (Data output, VBT Ver. 2)

- Connection with PLC

Please make the connection using the ANM81303 RS232C cable (see below) according to the following wiring example.

Since the wires on the PLC side of the RS232C cable are loose, please prepare them in accordance with the PLC you will be using. It may be necessary to make preparations for short circuits on PLCs; therefore, please make the connection after verifying the wiring example.

[ANM81303]

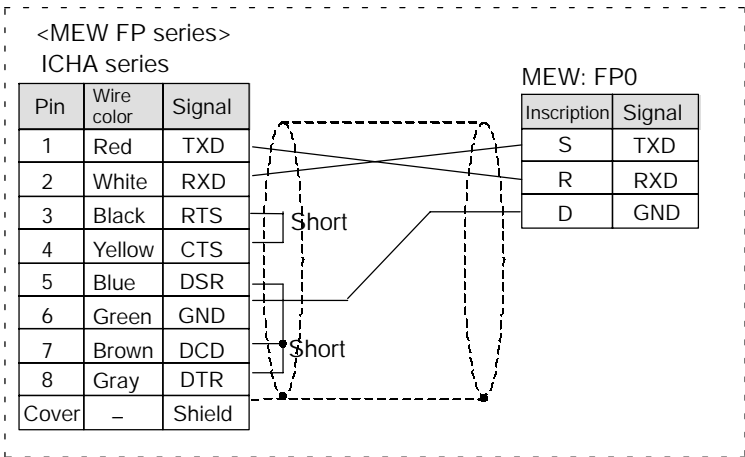
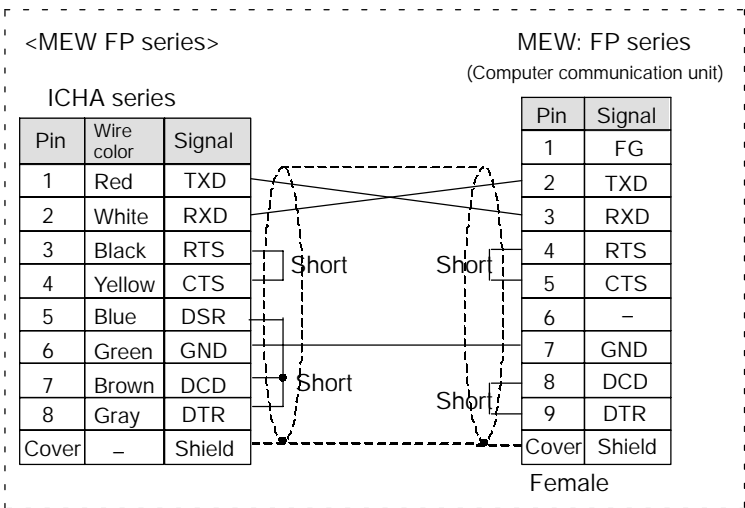
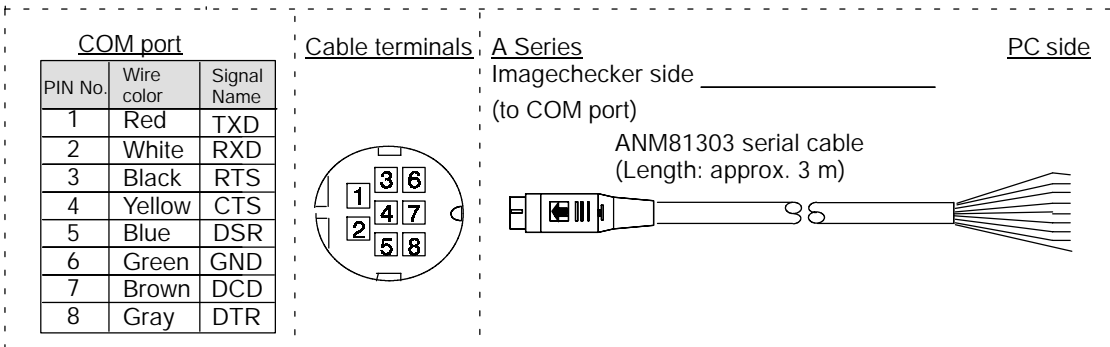

Example of connection with Mitsubishi PLC

Computer link transmission with Mitsubishi A series uses Format 4.

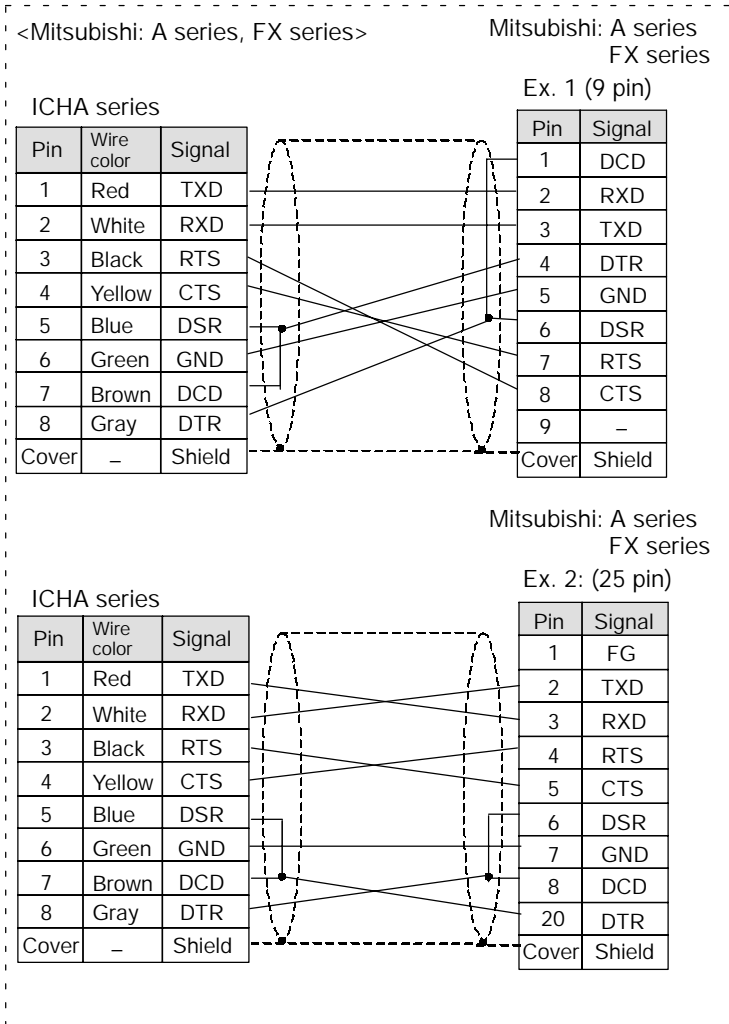

4.2 COM port (Data output, VBT Ver. 2)

Example of connection with Omron PLC

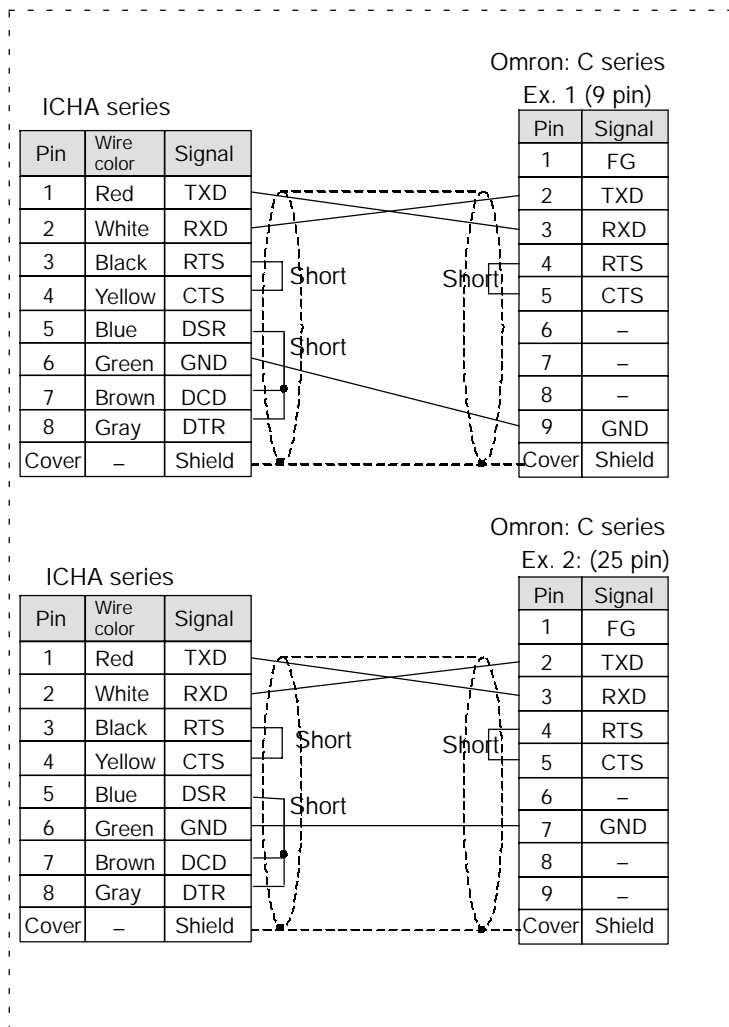

Example of connection with Allen-Bradley PLC

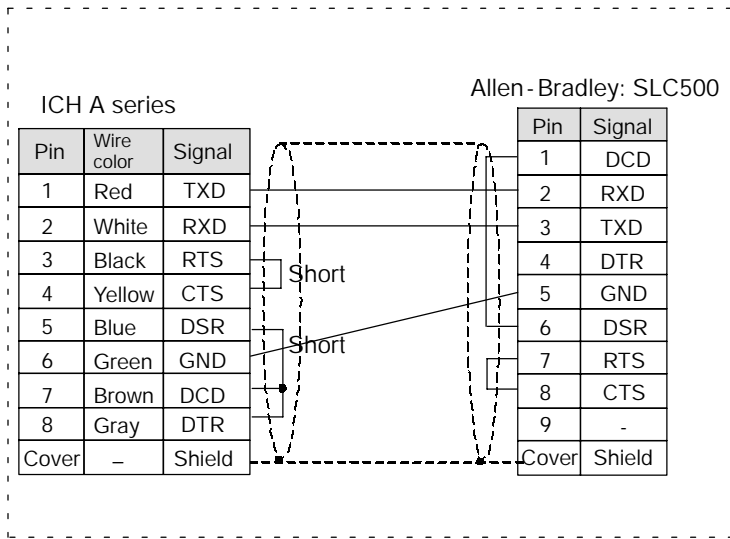

4.3 TOOL port (VBT Ver. 2 Port)

4.3 TOOL port (VBT Ver. 2 Port)

Terminal Positions

A Hoshiden - manufactured connector (part no. TCS7729) is used as the TOOL port on the controller unit.

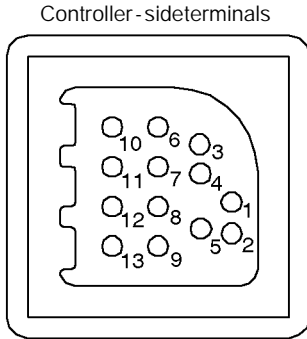

Pin No.	Signal Name	Pin No.	Signal Name
1	Used	8	Used
2	Used	9	Used
3	TxD	10	CTS
4	Used	11	RxD
5	Used	12	Used
6	RTS	13	Used
7	GND	Cover	Shield

Using the TOOL Port Correctly

The highlighted signals are reserved. Do not use them.

Wiring Examples

- Connection with an IBM PC -AT compatible

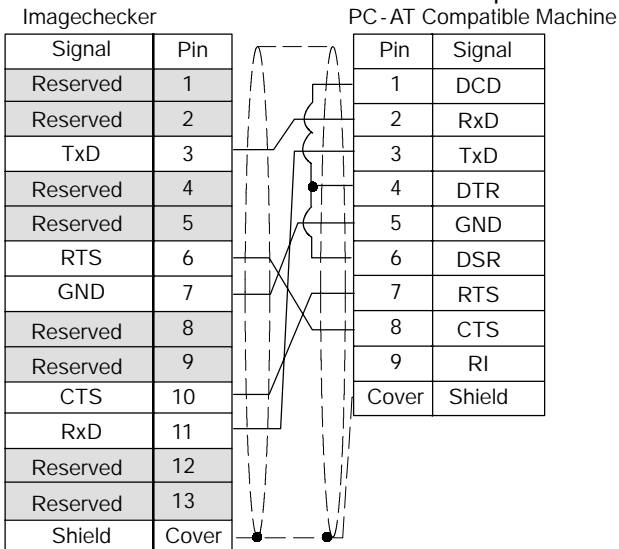

Connect as shown in the diagram on the left.

Use the ANM812001 with an off-the-shelf cross cable.

4.3 TOOL port (VBT Ver. 2 Port)

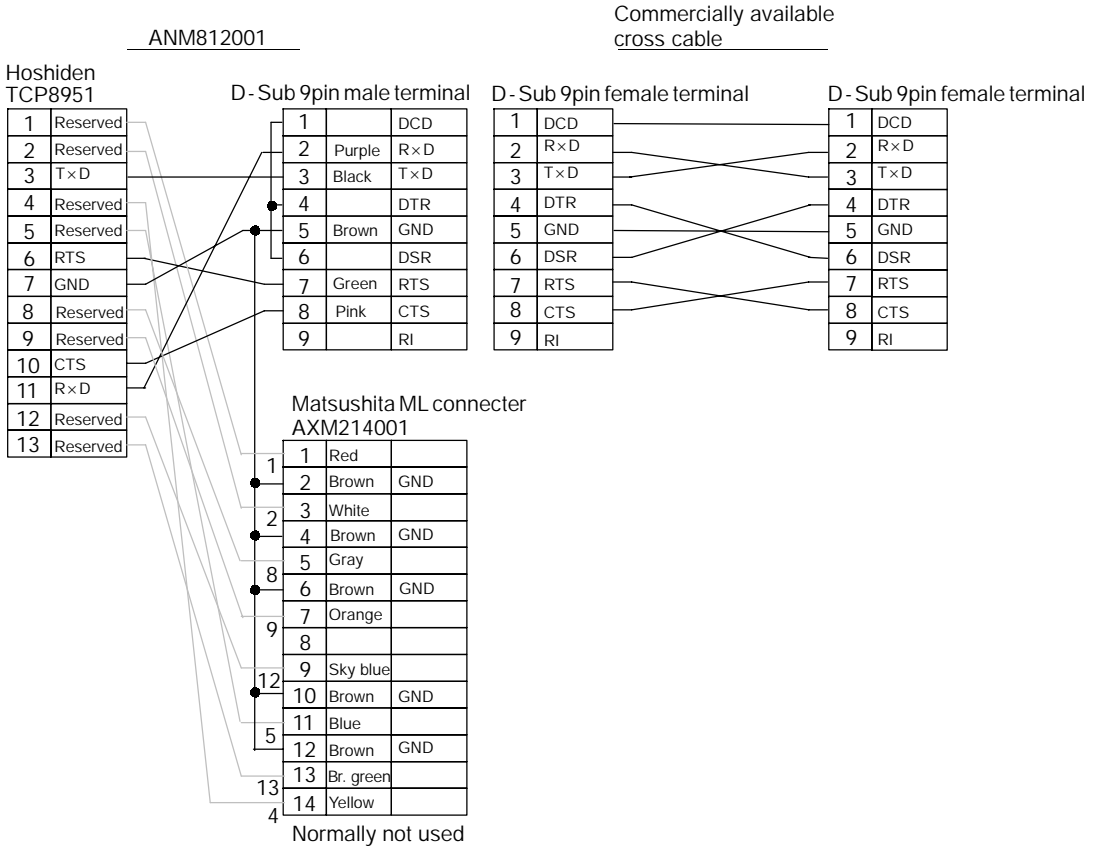
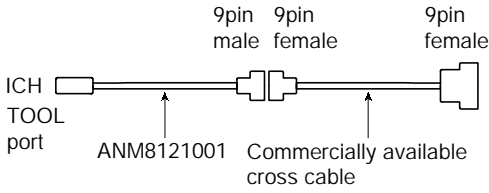

4.3 TOOL port (VBT Ver. 2 Port)

Chapter 5

About Camera Modes

5.1	<i>Camera Modes</i>	5 - 3
5.2	<i>Imaging Time for the Camera Modes (for memory image display) and Resolution</i>	5 - 4
5.3	<i>Frame Mode and Field Mode</i>	5 - 5

5.1 Camera Modes

Two of our cameras can be used with the A Series: The double - speed random camera, model ANM831, and the standard camera, model ANM832.

The A Series supports a total of six camera modes. The camera mode is set according to whether the inspection object is moving or still, whether the illumination is continuous or strobe, and the camera type.

Double - Speed Random Modes	<p>This mode uses the double - speed random camera ANM831. This mode is used when the light is continuous and imaging objects are either moving or still.</p> <p>The camera mode is switched between frame and field by setting items on a menu and changing the settings of the DIP switches on the back of the camera. See note 1).</p>	Frame Mode
		<p>Imaging time = (shutter speed) + (16.7ms). Images are processed at high resolution of 512 × 480 pixels.</p> <p>This is the fastest mode for taking 512 × 480 pixel images. (maximum of 3 times faster than previous models)</p>
Normal Modes	<p>These modes use a normal camera, model ANM832.</p> <p>This frame mode is used to image moving objects using strobe light.</p> <p>Either mode will support the imaging of still objects.</p>	Field Mode
		<p>Fast imaging time = (shutter speed) + (8.3ms). Images are processed at 512 × 240 pixel resolution.</p> <p>This is the fastest imaging mode. (maximum of 4 times faster than previous models)</p>
Internal Sync	<p>This mode uses NTSC signal input.</p> <p>The field mode is used for moving images. The frame mode is used for still images.</p>	Frame Mode
		<p>This mode can image still objects using continuous light or can image moving objects using strobe light.</p> <p>Imaging time = (33.3 to 49.9ms). Images are processed at high resolution of 512 × 480 pixels.</p> <p>When using strobe light, set this normal mode frame mode and switch the monitor display to Memory.</p>
		Field Mode
		<p>Imaging time = (16.7 to 33.3ms). Images are processed at 512 × 240 pixels.</p>
		Frame Mode
		<p>The mode captures still images using an NTSC signal.</p> <p>Imaging time = (shutter speed) + (33.3 to 49.9ms). Images are processed at high resolution of 512 × 480 pixels.</p>
		Field Mode
		<p>The mode captures moving images using an NTSC signal.</p> <p>Imaging time = (shutter speed) + (16.7 to 33.3ms). Images are processed at a resolution of 512 × 240 pixels.</p>

1) See the information about DIP switches on page 1 - 6.

5.2 Imaging Time for the Camera Modes (for memory image display) and Resolution

5.2 Imaging Time for the Camera Modes (for memory image display) and Resolution

	Frame	Field
Double-Speed Random	Imaging time = (shutter speed) + 16.7ms	Imaging time = (shutter speed) + 8.3ms
	Resolution = 512 × 480 pixels	Resolution = 512 × 240 pixels
	Supports moving and still objects, continuous light.	Supports moving and still objects, continuous light
	Camera = ANM831 To switch between frame and field modes, you must change the settings on the controller menu and change the DIP switch settings on the back of the camera. See note 1) Set the camera shutter speed from the controller menu.	
Normal Internal Sync	Imaging time = 33.3 to 50ms	Imaging time = 16.7 to 33.3ms
	Resolution = 512 × 480 pixels	Resolution = 512 × 240 pixels
	Supports still objects and continuous light. Supports moving objects with strobe light that uses the FLASH signal. See note 2)	Supports moving and still objects, continuous light.
	Camera = ANM832 See note 3) To switch between frame mode and field mode, change the settings on the controller menu. Set the camera shutter speed using the controller menu.	

- 1) See the information about DIP switches on page 1-6.
- 2) When using a strobe light, set to normal frame mode, and be certain to switch the monitor display to "Memory Display". If the monitor display is set to "Through Display", the strobe will flash continuously.
- 3) The internal sync is an NTSC signal input.

5.3 Frame Mode and Field Mode

Frame Mode

In this mode, the camera captures an even number array and an odd number array and sends them to the image processing system. In the A Series, all 512×480 pixels are sent to memory and are then subject to image processing. Compared to field mode this requires more imaging time, but the resolution is higher.

Field Mode

In this mode, the camera captures either an even number array or an odd number array and sends it to the image processing system. In the A Series, 512×240 pixels are captured, but are transferred to memory as 512×480 pixels and then image processed. Image capture is faster than in frame mode, but resolution is lower.

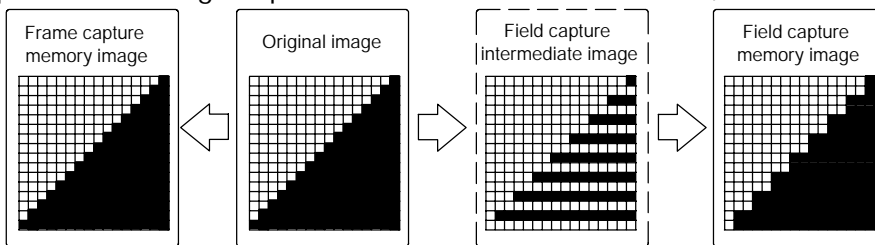

In the frame mode, the original image is captured into 256 level (8 bit) gray scale memory at a resolution of 512×480 pixels.

In the field mode:

1. Every other line (vertical) of the original camera image is captured into 256 level (8 bit) gray scale memory at a resolution of 512×240 pixels.
2. The uncaptured lines are added during display and image processing and the image is captured into a 256 level (8 bit) gray scale memory as a memory image, at a resolution of 512×480 pixels.

Using Frame and Field Modes Correctly

- Use memory image display for image display. Through Image Display takes an excessively long time to complete image capture. In addition, there is a large amount of dispersion in the image capture timing (max.: 33ms) for Double-speed Random modes.
- When connecting only one camera to the A200, connect it to Camera jack A.
- When connecting two cameras to the A200, they must be the same camera type, use the same mode, and have the same shutter speed.
- Be sure to turn OFF the power when connecting a camera to the controller.
- When using strobe light set the camera to normal field mode and be sure to switch the monitor display to Memory Display. The strobe will flash continuously if the monitor display is set to Through Display.
- During field mode or when using a random camera the sensitivity decreases in proportion to increases in shutter speed. Smears may increase. When Through images are displayed the monitor display will have fluctuating brightness. (This is not an indication of a problem. The brightness will be stable in the memory images.)
- Be sure to use illumination that is designed for image processing.

5.3 Frame Mode and Field Mode

Chapter 6

Product Type Data Creation and Backup

6.1 Product Type Data Creation and Backup 6- 3

6.1 Product Type Data Creation and Backup

Product type data is created with the special-purpose keypad. You can back up the created product type data together with image data stored on the controller to a *Windows PC, then restore the data later.

Keypad

This is an operational keypad that can be used with any A Series product. Nearly all settings can be made using this keypad.

A 2m or 3m cable is provided.

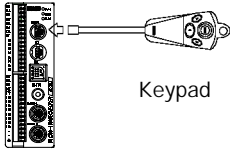

Vision Backup - Tool Version 2

You can use this tool to store (back up) created product type data to a Windows PC* and then to transfer (restore) it to the controller.

Even if created data was destroyed it can be quickly restored if has been backed up. Image data stored on the controller can also be stored on the Windows PC* in order to contribute credibility to an inspection "failure."

If an inspected product is assembled into equipment and shipped, then it doesn't work after installation, the "failed" image can be matched with the product type data and sent by e-mail so the malfunction can be analyzed anywhere.

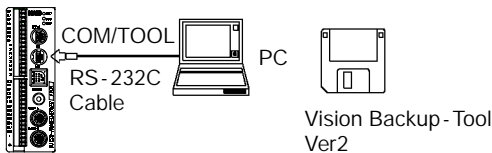

* Dedicated software for personal computers running the Windows operating system (running on IBM PC -AT or compatible PC).
Compatible with Windows 95/98/NT/Me/2000/XP.

6.1 Product Type Data Creation and Backup

Chapter 7

General Specifications

7.1	<i>Controller</i>	7 - 3
7.2	<i>Keypad</i>	7 - 4
7.3	<i>Monitor</i>	7 - 5
7.4	<i>Double-Speed Random Camera ANM831</i>	7 - 6
7.5	<i>CS-Mount Camera ANM832</i>	7 - 7

7.1 Controller

Item		Specification
Processing resolution		512 × 480 pixels (horizontal × vertical)
Processing function		Gray scale image/binarized image processing (details are determined by the application)
Settings		Special-purpose keypad
External interface	Serial	COM port: RS-232C TOOL port: RS-232C (can also be used to write programs for the A100P and A200P)
	Parallel input	Removable terminal block Input to 11 positions 12 V to 24 V DC input Bidirectional photocoupler
	Parallel output	Removable terminal block output to 14 positions
		NPN output type
	Photo-Mos output type	5 V to 24 V DC Photo-Mos relay output
Rated voltage		24 V DC
Operating voltage range		21.6 to 26.4 V DC (including ripples)
Number of connected cameras	A100 Series	1 camera
	A200 Series	Maximum 2 cameras
Standard power consumption		0.9A or less (when one camera is connected: 0.7A or less)
Operating temperature		0 to 50 deg. (avoid ice and condensation)
Monitor output		1 ch: NTSC output
Storage temperature		- 20 to 60 deg. (avoid ice and condensation)
Operating / storage humidity range		35 to 75%RH (avoid ice and condensation)
Noise resistance		1000 V pulse width 50ns/1μs (From a noise simulator. Note no keypad was connected)
Vibration resistance		10 to 55Hz, one vibration per minute, vibration width 0.75mm, 30 minutes each in X, Y, Z directions
Jolt resistance		196m/s ² , five times each in X, Y, Z directions
Weight		around 300g

7.2 Keypad

7.2 Keypad

Item	Specification
Operation buttons, lever	8 - direction lever, used jointly with the ENTER button: 1. A, B, C buttons = 1 each
Operating / storage humidity range	RH 35% to 75% (no icing or condensation)
Operating temperature	0 deg. to +50 deg. (no icing or condensation)
Storage temperature	- 20 deg. to +60 deg. (no icing or condensation)
Weight	Approx. 50g (excluding cable)

7.3 Monitor

Item	Specification	CE	Part Number
Monitor	100V AC specification Power code (length:1.5m), Monitor cable(length:3m) and BNC connector provided	- - -	ANMA810
Monitor cable (PIN - BNC)	Cable length : 3 m	- - -	ANM87303
	Cable length : 5 m	- - -	ANM87305
	Cable length : 10 m	- - -	ANM87310
	Cable length : 15 m	- - -	ANM87315
	Cable length : 20 m	- - -	ANM87320
BNC connector	Connector that has a BNC terminal instead of a pin terminal	- - -	ANM8606

7.4 Double-Speed Random Camera ANM831

7.4 Double-Speed Random Camera ANM831

Item	Specification
Imaging element	Readout of all pixels (interline transfer protocol) 1/3 inch CCD fixed photo elements
Effective pixels	Horizontal 659 pixels × vertical 494 pixels; pixel size = Square Pixel
Scanning method	Non-interlaced mode (1/60s) 2:1 interlaced (1/120s × 2) Switched mode (using DIP switches on camera back)
Shutter speeds:	OFF (1/120), 1/200, 1/500, 1/1000, 1/2000, 1/4000, 1/8000, and 1/20000s (Set by the controller)
Gain switch and adjustment	Gain switch = 0dB or gain up (DIP switch) Gain up volume is adjusted within the range of 0 to +10dB using the fine tuning knob on the back of the camera.
Lens mount	C mount
Rated voltage / Operating voltage range	12 V DC (supplied from the controller) 10.8 to 13.2 V DC
Consumed current	130mA
Operating temperature	Performance guarantee temperature range = 0 to 40 deg. (avoid ice and condensation) Operating temperature range = - 10 to 50 deg. (avoid ice and condensation)
Storage temperature	- 30 to 60 deg. (avoid ice and condensation)
Operating humidity range	Performance guarantee humidity range = 50 to 70%RH (avoid ice and condensation) Operating humidity temperature range = 30 to 70%RH (avoid ice and condensation)
Storage humidity	25 to 90%RH or less (avoid ice and condensation)
Vibration resistance	70m/s ² (10 to 55Hz, one hour each in X, Y, Z directions, fixed vibration width)
Jolt resistance	700m/s ² 6 directions
Weight	around 70g (excluding cables, lens, and camera mounting hardware)

7.5 CS-Mount Camera ANM832

Item	Specification
Imaging element	Interline transmission method 1/3 inch CCD solid state imaging element
Effective pixels	768 pixels (horizontal) × 492 pixels (vertical)
Scanning method	2:1 interlace (1/60s)
Accumulation	Frame accumulation
Shutter speed	OFF 1/60s, Electronic shutter = 1/100, 1/125, 1/500, 1/1000, 1/2000, 1/4000, and 1/10000s (Set by the controller)
Synchronization	External synchronization
Lens mount	CS mount
Rated voltage / Operating voltage range	12 V DC (supplied from the controller) 10.8 to 13.2 V DC
Consumed current	140mA
Operating temperature	0 deg. to + 40 deg. (no icing or condensation)
Storage temperature	- 30 deg. to + 60 deg. (no icing or condensation)
Operating humidity range	RH 35% to 85% (no icing or condensation)
Storage humidity	RH 85% or less (no icing or condensation)
Vibration resistance	10 to 55Hz, 1 vibration per minute, vibration width 1.2mm, 30 minutes each in X, Y, Z directions.
Jolt resistance	700m/s ² , three times each in X, Y, Z directions
Weight	Approx. 450g (excluding lens and holder)

7.5 CS-Mount Camera ANM832

Chapter 8

Part Numbers

8.1	<i>Controllers</i>	8 - 3
8.2	<i>Cameras</i>	8 - 5
8.3	<i>Double-Speed Random Camera Cable</i>	8 - 6
8.4	<i>Camera Extension Cable</i>	8 - 7
8.5	<i>Keypad</i>	8 - 8
8.6	<i>Monitor</i>	8 - 9
8.7	<i>Data Backup Software and PC Cable</i>	8 - 10
8.8	<i>Lenses and Adapter Rings</i>	8 - 11
8.9	<i>Lighting for Image Processing</i>	8 - 12

8.1 Controllers

Item	Specification		CE	Part Number
Micro-Imagechecker A200 series	Multichecker V2	NPN Output Initial display : Japanese Includes Japanese manual	Conformed	ANMA210 V2
		NPN Output Initial display : English Includes English manual	Conformed	ANMA212 V2
		Photo MOS Output Initial display : English No manual	Conformed	ANMA213 V2
		Photo MOS Output Initial display : English Includes English manual	Conformed	ANMA218 V2
	Multichecker	NPN Output Initial display : Japanese Includes Japanese manual	Conformed	ANMA210
		NPN Output Initial display : English Includes English manual	Conformed	ANMA212
		Photo MOS Output Initial display : English No manual	Conformed	ANMA213
	OCV checker	NPN Output Initial display : Japanese Includes Japanese manual	Conformed	ANMA220
		NPN Output Initial display : English Includes English manual	Conformed	ANMA222
		Photo MOS Output Initial display : English No manual	Conformed	ANMA223
		Photo MOS Output Initial display : English Includes English manual	Conformed	ANMA228
	Micro-Imagechecker A100 series	Multichecker V2	NPN Output Initial display : Japanese Includes Japanese manual	Conformed
NPN Output Initial display : English Includes English manual"			Conformed	ANMA112 V2
Photo MOS Output Initial display : English No manual			Conformed	ANMA113 V2
Photo MOS Output Initial display : English Includes English manual			Conformed	ANMA118 V2

 next page

8.1 Controllers

Item	Specification		CE	Part Number
Micro-Imagechecker A100 series	Multichecker	NPN Output Initial display : Japanese Includes Japanese manual	Conformed	ANMA110
		NPN Output Initial display : English Includes English manual	Conformed	ANMA112
		Photo MOS Output Initial display : English No manual	Conformed	ANMA113
Spare Input/Output Terminal Blocks (for repairs)	Spare Input/Output Terminal Blocks (1 for input, 1 for output)		N/A	ANMA8001

8.2 Cameras

Item	Specification	CE	Part Number
Double-speed random camera	Double-speed random camera	Conformed	ANM831
CS-mount camera	CS-mount camera	Not conformed	ANM832
			ANM83203 *1)
		Conformed	ANM832CE

*1) Although ANM83203 is the same specification as ANM832, only the length of a cable has a difference in both. Please refer to chapter 9.

8.3 Double-Speed Random Camera Cable

8.3 Double-Speed Random Camera Cable

Item	Specification	CE	Part Number
ANM831 camera cable	3m	Not conformed	ANM84303
	3m: CE compliant	Conformed	ANM84303CE

Use the camera extension cable when extending the double-speed random camera's cable 3 meters or more.

The length of a cable with CE is short a little.

8.4 Camera Extension Cable

Item	Specification	CE	Part Number
Extension cable for ANM831/ANM832 (CE)	Extension cable = 2m: total 5m	Not conformed	ANM84002A
	Extension cable = 7m: total 10m	Not conformed	ANM84007A
	Extension cable = 12m: total 15m	Not conformed	ANM84012A
	Extension cable = 17m: total 20m	Not conformed	ANM84017A
	Extension cable = 2m: total 5m: CE compliant	Conformed	ANM84002ACE
	Extension cable = 7m: total 10m: CE compliant	Conformed	ANM84007ACE
	Extension cable = 12m: total 15m: CE compliant	Conformed	ANM84012ACE
	Extension cable = 17m: total 20: CE compliant	Conformed	ANM84017ACE

The length of a cable with CE is short a little.

8.5 Keypad

8.5 Keypad

Item	Specification	CE	Part Number
Keypad for A/M series	Cable length = 2m	Not conformed	ANM85202
	Cable length = 3m	Not conformed	ANM85203
	Cable length = 5m	Not conformed	ANM85205
	Cable length = 10m	Not conformed	ANM85210
	Cable length = 2m: CE	Conformed	ANM85202CE
	Cable length = 3m: CE	Conformed	ANM85203CE
	Cable length = 5m: CE	Conformed	ANM85205CE
	Cable length = 10m: CE	Conformed	ANM85210CE

The length of a cable with CE is short a little.

8.6 Monitor

Item	Specification	CE	Part Number
Monitor	100 V AC specification, monitor cable provided. Panasonic -made GPBM910 monitor.	Not conformed	AUGPBM910
BNC connector	Connector that has a BNC terminal instead of a pin terminal	N/A	ANM8606

8.7 Data Backup Software and PC Cable

8.7 Data Backup Software and PC Cable

Item	Specification	CE	Part Number
Data backup software	Vision Backup Tool Version 2 (for A/M series) Supports Japanese language, runs under Windows.	N/A	ANM7013V2
	Vision Backup Tool Version 2 (for A/M series) Supports English, runs under Windows.		ANM70131V2
COM port RS-232C cable for connecting with a PC	D-SUB 9 pin connection RS-232C cable (3m) for connecting the COM port with a PC-AT compatible machine	Conformed	ANM81103
	Parallel cable (3) for connecting the COM port with a PLC.	Conformed	ANM81303
RS-232C cable for connecting the TOOL port with a PC	D-SUB 9 pin connection RS-232C cable (10cm) for connecting the TOOL port with a PC-AT compatible machine.	Conformed	ANM812001

- Supported operating systems are Windows 95/98/NT/Me/2000/XP.
- The ANM81103 is a cable that has connectors that link the A series COM port with a PC.
- The ANM81303 is a parallel cable that connects the A series COM port with a PC. Use it by matching the parallel line portion to the connected PLC.
- The ANM812001 cable connects the A Series (TOOL port) to a PC (VBT Ver. 2 and RS-232C).
- When connecting to a PC, use an off-the-shelf D-SUB 9-pin cross extension cable.

8.8 Lenses and Adapter Rings

Item	Specification	Specification	CE	Part Number
C Mount Lenses	f6.5 lens	- - - - -	N/A	ANB842
	f8.5 lens	With lock		ANB843L
		- - - - -		ANB843
	f16 lens	With lock		ANB845NL
		- - - - -		ANB88161
		- - - - -		ANB845N
	f25 lens	With lock		ANB846NL
		- - - - -		ANB88251
		- - - - -		ANB846N
	f50 small lens	With lock		ANM88501
		- - - - -		ANM8850
	f50 lens	With lock		ANB847L
- - - - -		ANB847		
CS Mount Lenses	f2.8 small lens	With lock	ANM88281	
		- - - - -	ANM8828	
	f4 small lens	With lock	ANM88041	
		- - - - -	ANM8804	
	f8 small lens	With lock	ANM88081	
		- - - - -	ANM8808	
Adapter rings	5mm adapter ring		ANB84805	
	Ring set (0.5, 1, 5, 10, 20, 40mm)		ANB848	

Use a lockable lens in order to lock focal distance and exposure adjustment rings into place.

8.9 Lighting for Image Processing

8.9 Lighting for Image Processing

Item	Specification		Part Number	
LED	Direct light (ring)	Dia. 50mm direct ring light	AULDR2-50RD	
		Dia. 70mm direct ring light	AULDR2-70RD	
	Options for direct light (ring)	For AULDR2-50RD	Polarizing plate	AUPL-LDR-50B
			Diffusing plate	AUDF-LDR-50B
		For AULDR2-70RD	Installation adapter	AUAD-LDR-50B
			Polarizing plate	AUPL-LDR-70A
	Indirect (light conducting) ring light	Dia. 74 indirect (light conducting) ring light	AULKR-70A	
		Dia. 102 indirect (light conducting) ring light	AULFR-100	
	Penetration light (flat)	Flat light(27 by 27 light source)	AULDL-TP2727	
		Flat light(43 by 35 light source)	AULDL-TP4335	
		Flat light(80 by 100 light source)	AULFL-100	
	Coaxial light	Coaxial light (26 by 28 translucent glass size)	AULFV-34	
		Coaxial light (32 by 36 translucent glass size)	AULFV-50A	
	Power supply	Digital power supply Output: 1ch (switchable 12V/24V), 10W	ANB86001	
		Digital power supply Output: 2ch (switchable 12V/24V), 30W	ANB86003	
		Digital power supply (Output: 12V / 9.5 W)	AUPD-1012	
Extension cable	for 12V (Cable length: 3m)	AUCB-3		
	for 24 V (Cable length: 3m)	AUFCB-3		
Inverter ring light (100 V AC)	Dia. 60 ring light		ANMF0064	
	Dia. 92 ring light		ANMF0104	
	Dia. 60 ring light (ANMF0064) replacement lamp		ANMF0060	
	Dia. 92 ring light (ANMF014) replacement lamp		ANMF0100	
Halogen light source (100 V AC)	50W light source lamp housing		ANMH105	
	100W light source lamp housing		ANMH110	
	50W light source lamp housing (ANMH105) replacement lamp		ANMH305	
	100W light source lamp housing (ANMH110) replacement lamp		ANMH310	
Fiber light guide	Ring light guide		ANMH200	
	Straight light guide		ANMH210	
	2-branch light guide		ANMH220	
	Flat light guide		ANMH240	
Adapter	Light guide adapter for use in connecting an ANMH240 to an ANMH110.		ANMH800	

Chapter 9

Dimension diagram

9.1	<i>Controller</i>	9 - 3
9.2	<i>Camera</i>	9 - 4
9.2.1	<i>Double-Speed Random Camera ANM831</i> .	9 - 4
9.2.2	<i>CS-Mount Camera ANM832</i>	9 - 4
9.3	<i>Camera Cable and Camera Extension Cable</i>	9 - 5
9.4	<i>Keypad</i>	9 - 6
9.5	<i>Monitor: AUGPBM910 (100 V AC specifications)</i> ...	9 - 7
9.6	<i>Lenses</i>	9 - 8

9.1 Controller

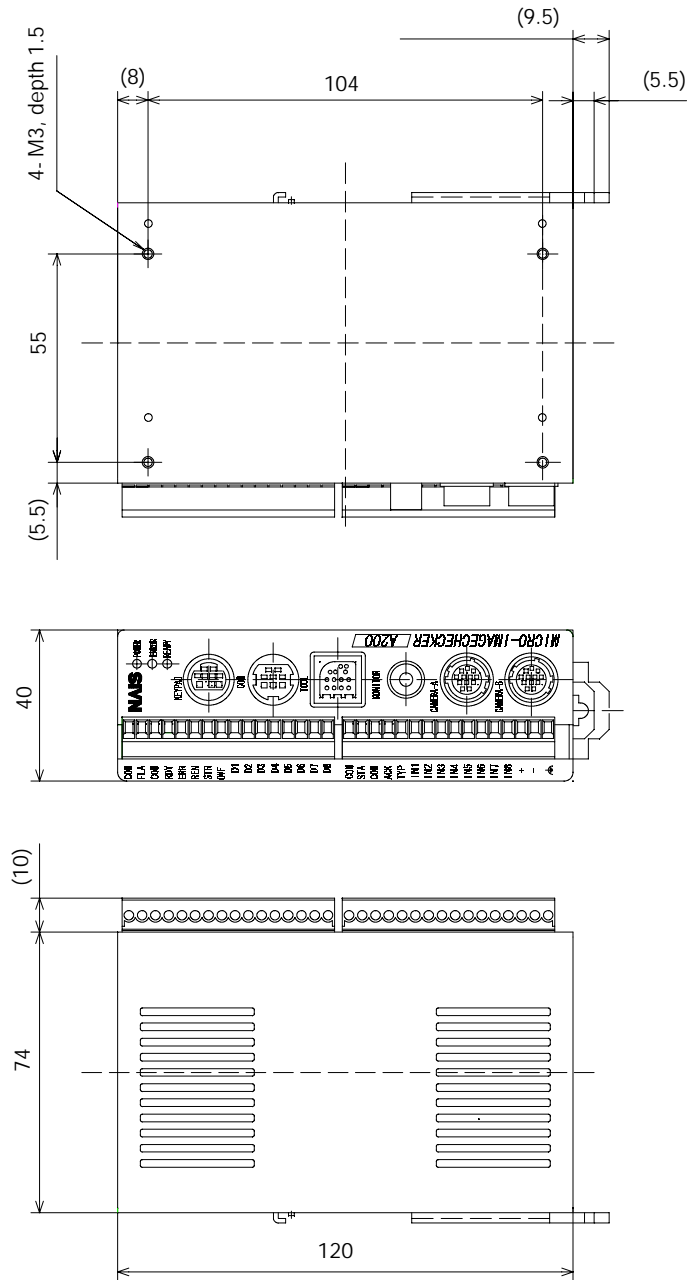

*Only one camera can attach to the A100. It does not have a Camera B port.

Unit: mm

9.2 Camera

9.2 Camera

9.2.1 Double-Speed Random Camera ANM831

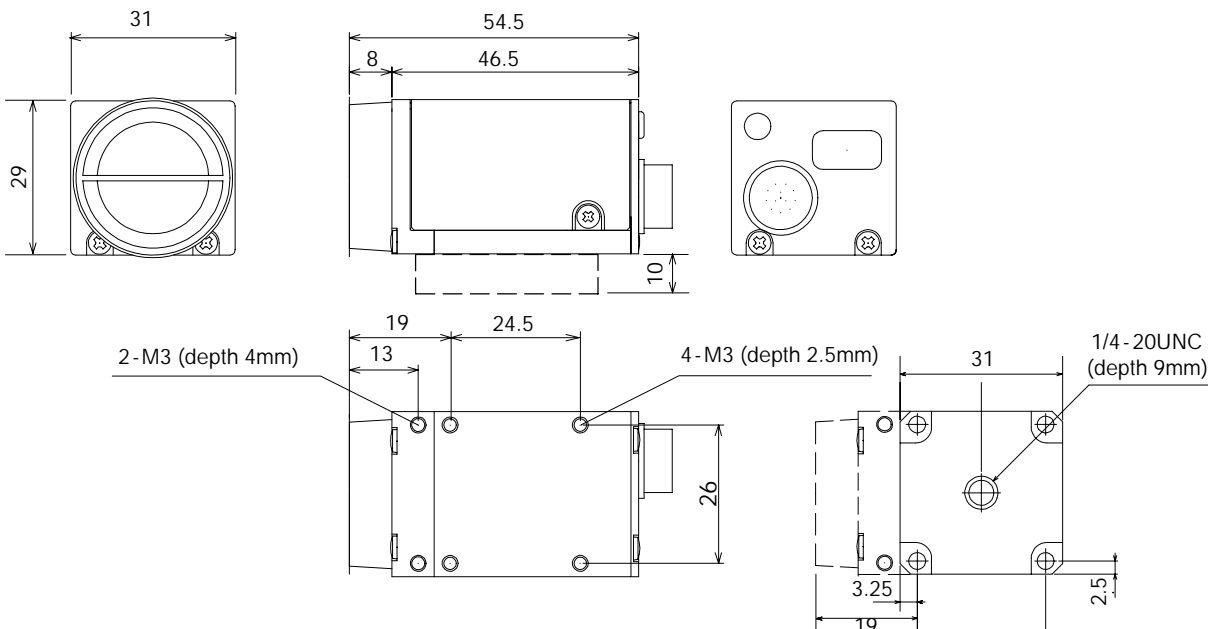

9.2.2 CS-Mount Camera ANM832

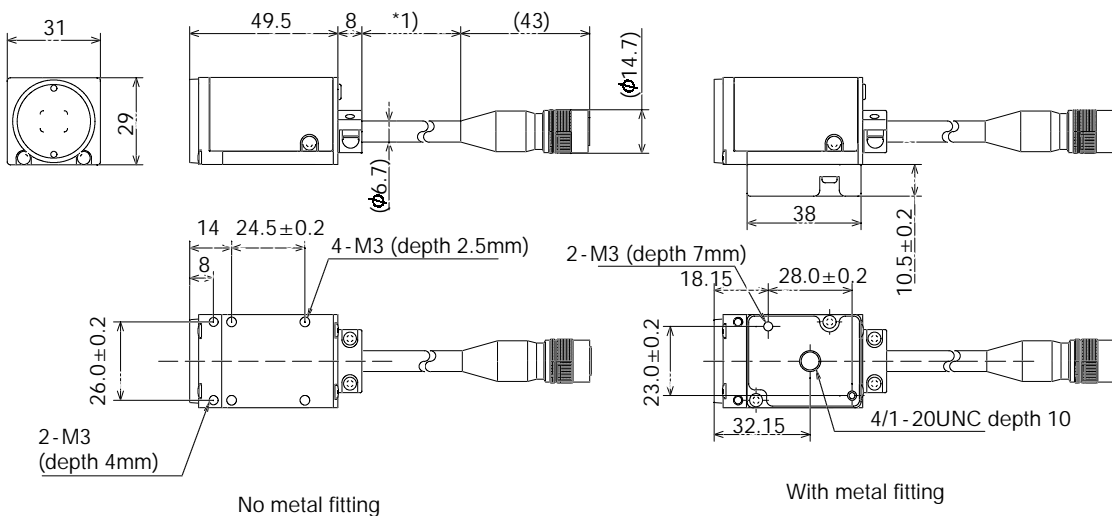

*1) ANM832: 3000 $\begin{matrix} +80 \\ -10 \end{matrix}$ ANM83203: 300 $\begin{matrix} +40 \\ -10 \end{matrix}$

9.3 Camera Cable and Camera Extension Cable

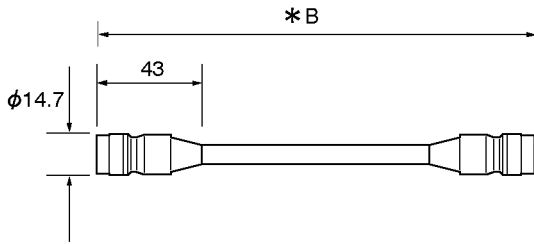

*B is the length of the installed cable.

The length of a cable with CE is short a little.

9.4 Keypad

9.4 Keypad

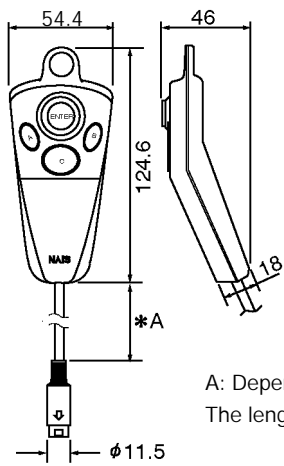

A: Depends on the installed keypad.
The length of a cable with CE is short a little.

9.5 Monitor: ANMA810

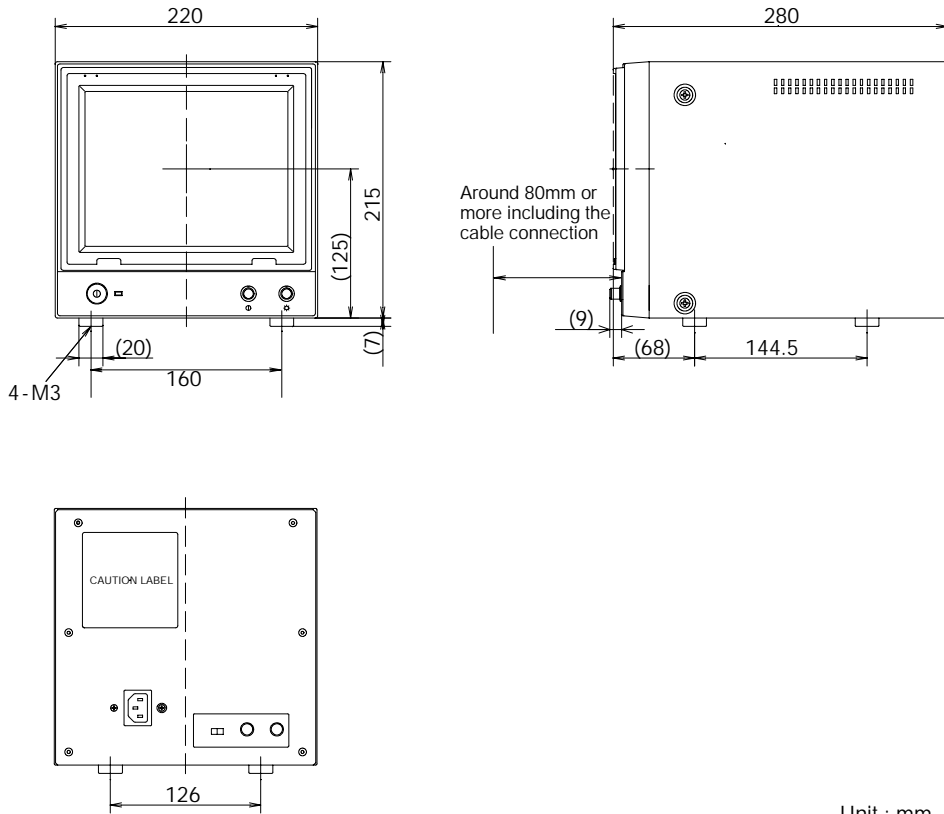

Note

Reserve at least 80mm of space to the rear of the monitor to facilitate wiring and heat dissipation.
Input/output to the monitor is with a BNC terminal.

9.6 Lenses

9.6 Lenses

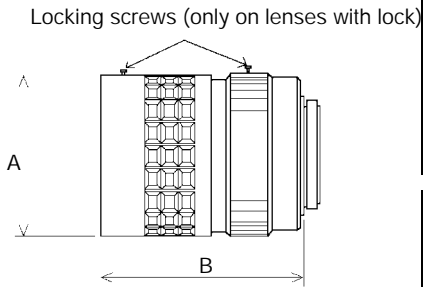

C mount lenses		A	B
ANB842	f=6.5	φ48	42
ANB843(L)	f=8.5	φ42	40
ANB845N(L)	f=16	φ30	33
ANB846N(L)	f=25	φ30	37.3
ANB88161	f=16	φ30.5	25
ANB88251	f=25	φ30.5	25.5
ANB847(L)	f=50	φ48	48
ANM8850	f=50	φ27.5	38.5
ANM88501	f=50	φ30.5	38.5

CS mount lenses		A	B
ANM8808	f=8	φ34	35
ANM88081	f=8	φ31	35
ANM8804	f=4	φ34	41
ANM88041	f=4	φ31	40
ANM8828	f=2.8	φ34	38
ANM88281	f=2.8	φ31	37.5

Dimensions

ANM8850

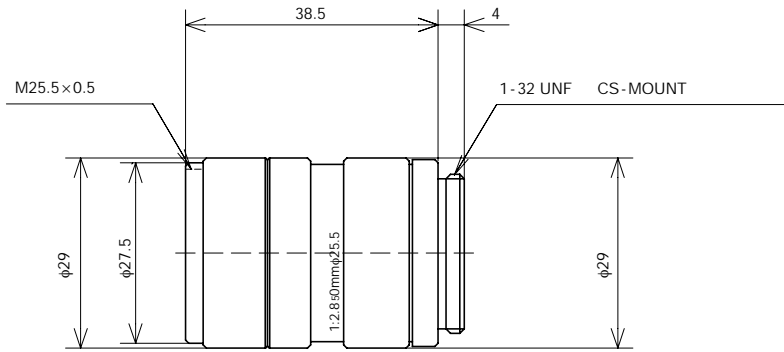

ANM88501

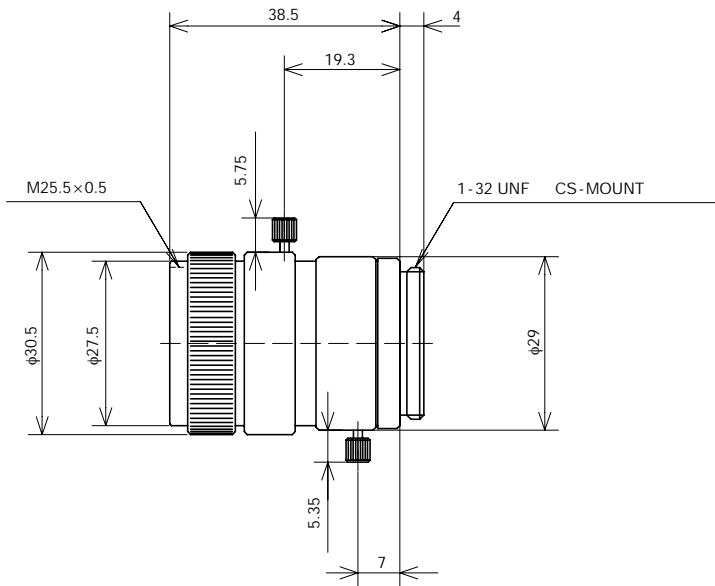

ANM8808

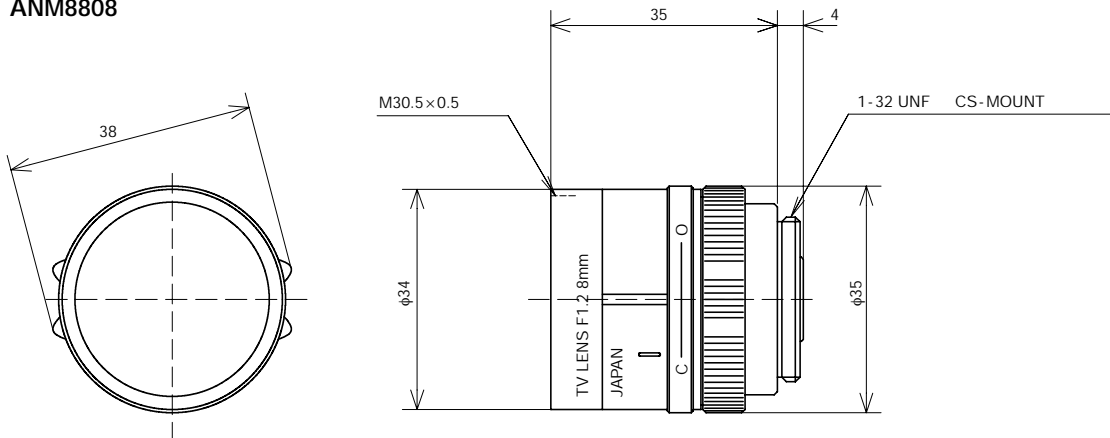

9.6 Lenses

ANM88081

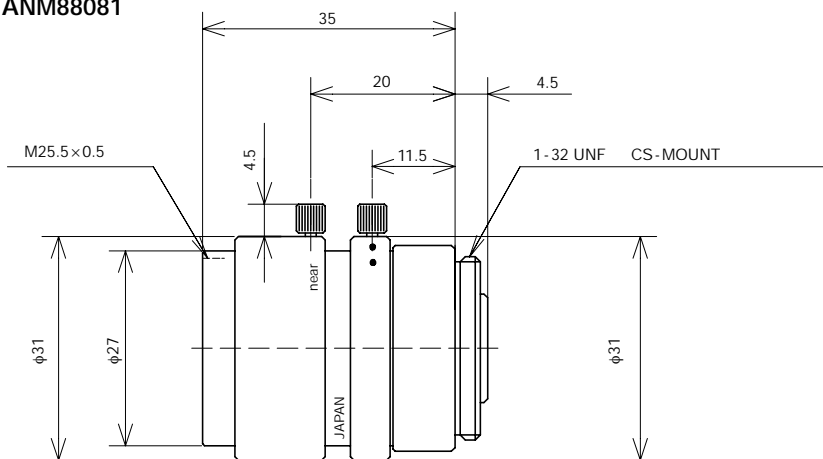

ANM8804

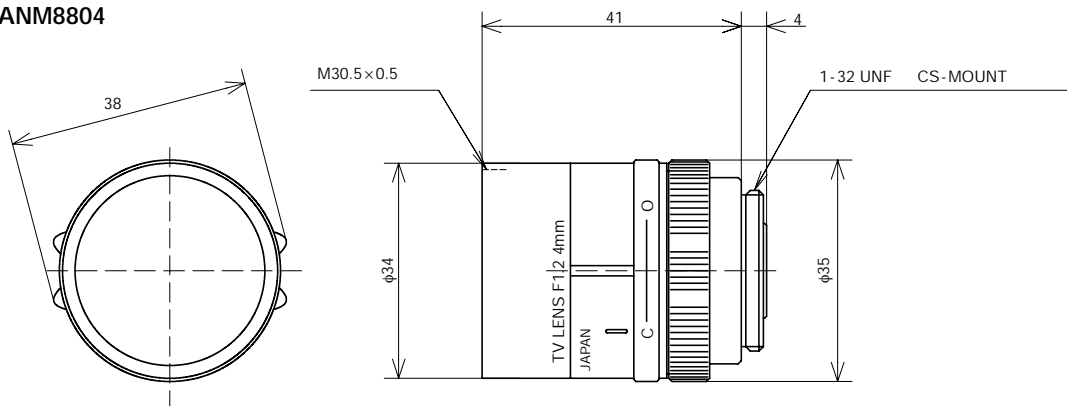

ANM88041

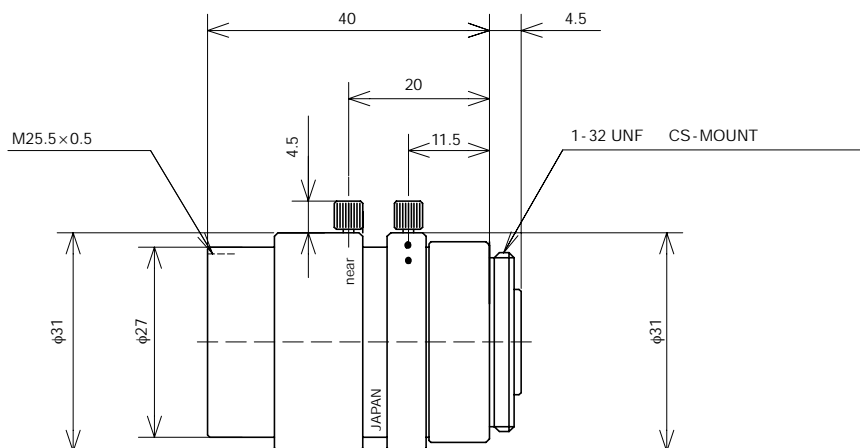

ANM8828

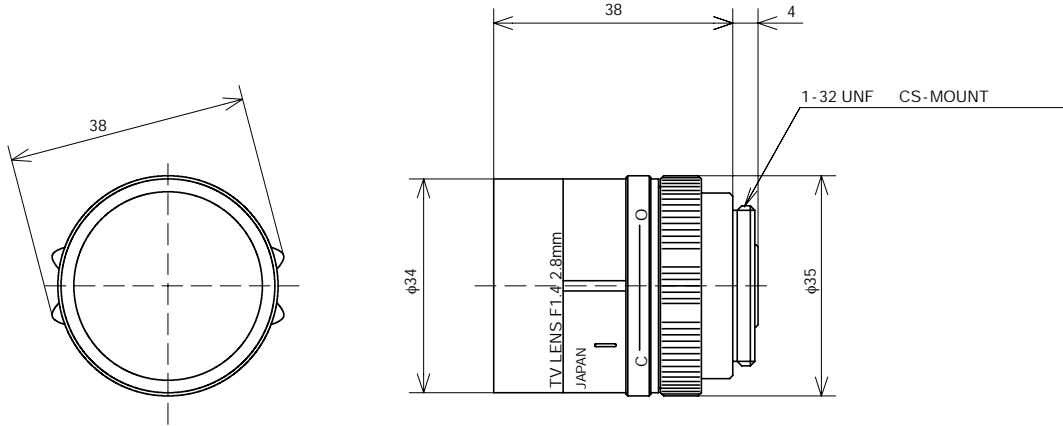

ANM88281

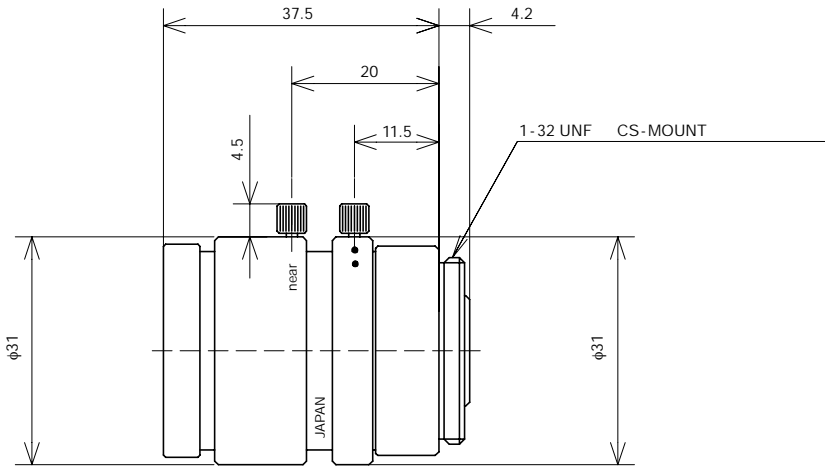

9.6 Lenses

Chapter 10

Pin Assignment

<i>10.1 Camera Pin Positions (ANM831)</i>	<i>10- 3</i>
<i>10.2 Camera Pin Positions (ANM832)</i>	<i>10- 4</i>

10.1 Camera Pin Positions (ANM831)

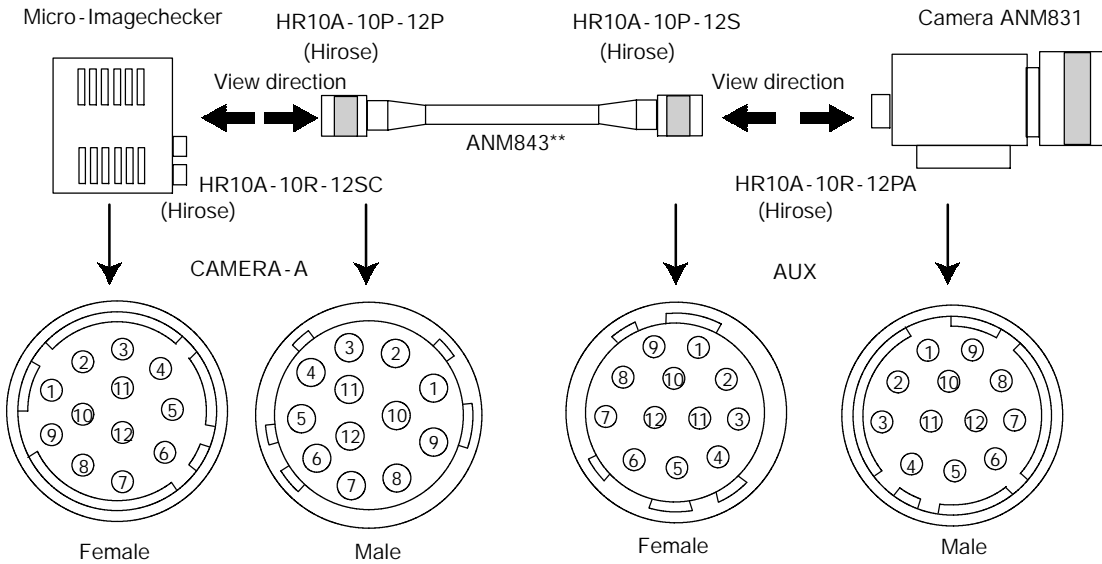

No.	Signal Name
1	POWER GND
2	+12V
3	Video shield
4	VIDEO
5	HD shield
6	HD

No.	Signal Name
7	SHT3
8	SHT1
9	SHT2
10	SHT GND
11	TRIGGER
12	VD shield
Case	Encasement shield

No.	Signal Name
2	+12V
1	POWER GND
4	VIDEO
3	Video shield
6	HD
5	HD shield
7	SHT3
12	GND
8	SHT1
9	SHT2
11	TRIGGER
10	SHT GND
Case	Encasement shield

Signal Name	No.
+12V	2
POWER GND	1
VIDEO	4
Video shield	3
HD	6
HD shield	5
SHT3	7
GND	12
SHT1	8
SHT2	9
TRIGGER	11
SHT GND	10
Encasement shield	Case

10.2 Camera Pin Positions (ANM832)

10.2 Camera Pin Positions (ANM832)

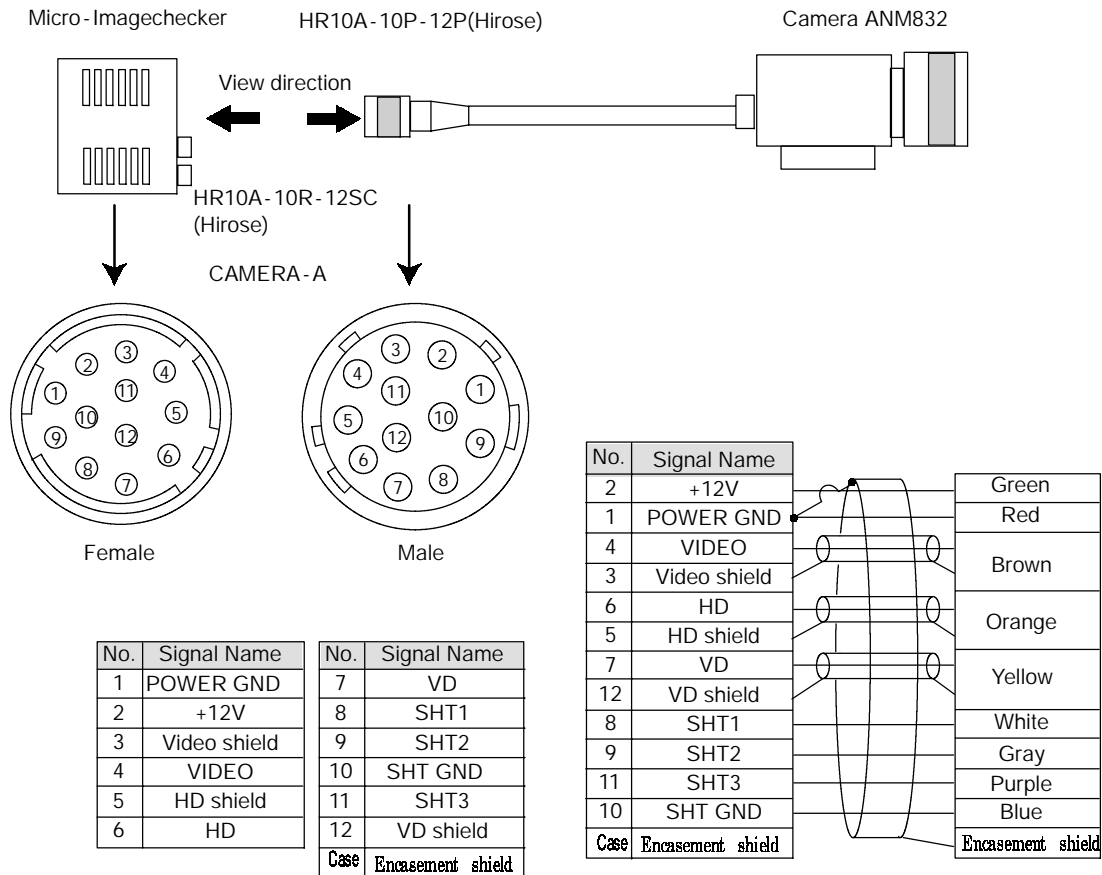

Chapter 11

Manual revision history

<i>11.1 Manual revision history</i>	<i>11- 3</i>
---	--------------

11.1 Manual revision history

Manual No.	Issue date	Description of changes
ARCT1F317E	Sep. 1999	First edition
	Sep. 1999	2nd edition: Corrections and camera pin arrangement added
	Oct. 1999	3rd edition: Corrections and part number added
	Nov. 1999	4th edition: Internal synchronous mode added
	Apr. 2000	Printed and bound edition: Corrections added
ARCT1F317E - 1	Aug. 2000	Corrections associated with upgrade to Ver. 1.2 of the A200/A100 MultiChecker.
	Sep. 2000	Printed and bound edition: Corrections added
ARCT1F326E	Oct. 2000	Corrections added
	Jul. 2001	Added content - A200 series OCV checker - LED for image processing - COM port and example of connection to PLC - Multichecker V2 part number - Part number change of camera extension cable. Addition of OS compatible with VBT Ver. 2.
	Oct. 2001	Printed and bound edition Added content - Lens f=16, f=25 - Camera ANM832
ARCT1F326E - 1	Oct. 2001	Printed and bound edition Added content - Lens f=16, f=25 - Camera ANM832
ARCT1F326E - 2	Jun. 2002	GENERAL INSTRUCTIONS "Before Creating Type Data" corrected Chapter 2 Page 9 and 10 "View range and Lens Selection Tables" corrected
ARCT1F326E - 3	Jan. 2003	4th edition
ARCT1F326E - 4	Feb. 2004	Changed : Monitor - AUGPBM910 to ANMA810

Several errors were found in the MICRO-IMAGECHECKER A200/A100 Hardware Manual ARCT1F326E-4. The correctness of these errors is as follows:

General Specification on page 7-5

7.3 Monitor: ANMA810

Item	Specification
Rated voltage	100 V AC
Operating voltage range	90 to 120 V AC
Power consumption	30 W or less
CRT	9 inch, White
Operation frequency	Horizontal: 15.734 kHz Vertical: 59.94 Hz
Input level	1.0 Vp-p (Video signal: 0.7 Vp-p positive polarity Synchronization signal: negative polarity)
Input impedance	75 Ω / High impedance, Bridge connection is available
Connector	BNC connector
Vibration resistance	10 to 100 Hz one sweep per minute amplitude 1 mm (10 to 22.3 Hz) acceleration 9.8 m/s ² (22.3 to 100 Hz) 30minutes each in X, Y and Z directions
Operating temperature	0 to +40 °C (avoid ice and condensation)
Storage temperature	-20 to +60 °C (avoid ice and condensation)
Operating humidity range	35 to 75 % RH (avoid ice and condensation)
Storage humidity range	35 to 75 % RH (avoid ice and condensation)
Weight	Approx. 6 kg

Part Numbers on page 8-9

8.6 Monitor: ANMA810

Item	Specification	CE	Part Number
Monitor	Power code (length: 1.5m), Monitor cable (length: 3m) and BNC connector provided	Not confirmed	ANMA810
Monitor cable (PIN-BNC)	Cable length: 3m		ANM87303
	Cable length: 5m		ANM87305
	Cable length: 10m		ANM87310
	Cable length: 15m		ANM87315
	Cable length: 20m		ANM87320
BNC connector	Connector that has a BNC terminal instead of a PIN terminal	N/A	ANM8606