

Panasonic®

PROGRAMMABLE CONTROLLER
FP0 Analog I/O Unit
Technical Manual

FP0 Analog I/O Unit Technical Manual
ARCT1F390E '04.2

Safety Precautions

Observe the following notices to ensure personal safety or to prevent accidents.

To ensure that you use this product correctly, read this User's Manual thoroughly before use.

Make sure that you fully understand the product and information on safe.

This manual uses two safety flags to indicate different levels of danger.

WARNING

If critical situations that could lead to user's death or serious injury is assumed by mishandling of the product.

- Always take precautions to ensure the overall safety of your system, so that the whole system remains safe in the event of failure of this product or other external factor.
- Do not use this product in areas with inflammable gas. It could lead to an explosion.
- Exposing this product to excessive heat or open flames could cause damage to the lithium battery or other electronic parts.

CAUTION

If critical situations that could lead to user's injury or only property damage is assumed by mishandling of the product.

- To prevent abnormal exothermic heat or smoke generation, use this product at the values less than the maximum of the characteristics and performance that are assured in these specifications.
- Do not dismantle or remodel the product. It could lead to abnormal exothermic heat or smoke generation.
- Do not touch the terminal while turning on electricity. It could lead to an electric shock..
- Use the external devices to function the emergency stop and interlock circuit.
- Connect the wires or connectors securely.
The loose connection might cause abnormal exothermic heat or smoke generation
- Do not allow foreign matters such as liquid, flammable materials, metals to go into the inside of the product. It might cause exothermic heat or smoke generation.
- Do not undertake construction (such as connection and disconnection) while the power supply is on.

Copyright / Trademarks

- This manual and its contents are copyrighted.
- You may not copy this manual, in whole or part, without written consent of Matsushita Electric Works, Ltd.
- Windows and Windows NT are registered trademarks of Microsoft Corporation in the United States and/or other countries.
- All other company names and product names are trademarks or registered trademarks of their respective owners.
- Matsushita Electric Works, Ltd. pursues a policy of continuous improvement of the Design and performance of its products, therefore, we reserve the right to change the manual/ product without notice.

Table of Contents

1	<i>Parts and Terminology</i>	3
1.1	<i>Analog Mode Switch Setting</i>	4
1.2	<i>Analog I/O Terminal</i>	4
2	<i>Specifications</i>	5
2.1	<i>General Specifications</i>	5
2.1.1	<i>Weight</i>	5
2.2	<i>Analog Input Specifications</i>	6
2.3	<i>Analog Output Specifications</i>	8
3	<i>A/D Conversion Characteristics</i>	9
4	<i>D/A Conversion Characteristics</i>	12
5	<i>Wiring</i>	13
5.1	<i>Analog Input Wiring</i>	13
5.2	<i>Analog Output Wiring</i>	14
6	<i>Boosting the Precision of the Thermocouple Range</i>	16
7	<i>Averaging Function</i>	17
7.1	<i>Averaging for Voltage Ranges and Current Ranges</i>	17
7.2	<i>Averaging for a Thermocouple Range</i>	18
8	<i>Analog I/O Unit Programs</i>	20
9	<i>Dimensions</i>	22

1 Parts and Terminology

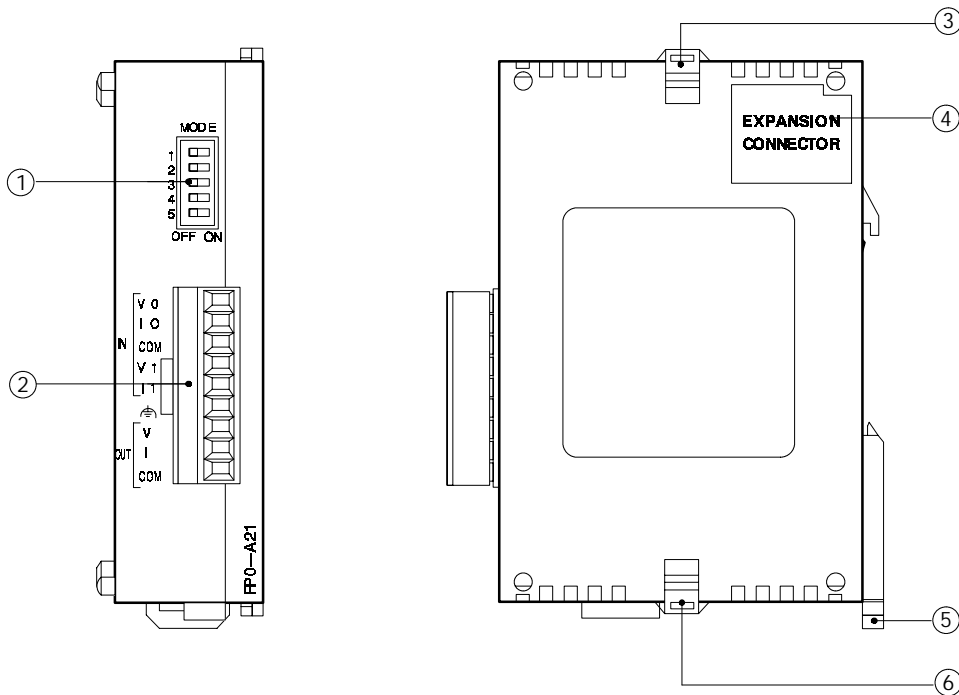

① Analog mode switch

is used to switch between input and output modes (voltage/current). With the analog I/O unit, both input channels are operated in the same range (*section 1.1.).

② Analog I/O terminal (9-pin)

Use a terminal block socket made by Phoenix Contact Co. (product number: 1840434) (*section 1.2 and See FP0 User's Manual).

③ ⑥ Expansion hook

is used to secure expansion units.

④ Expansion connector

connects an expansion unit to the internal circuit of the analog I/O unit (See FP0 User's Manual).

⑤ DIN rail attachment lever

allows simple attachment to a DIN rail. The lever is also used for installation on FP0 slim type mounting plate (AFP0803).

1 Parts and Terminology

1.1 Analog Mode Switch Setting

Analog mode switch

Mode	Switch number	Range										
Analog input range switching	1 to 3, 5	0 to 5V 0 to 20mA	- 10 to +10V		K type thermocouple (* Note 3)		J type thermocouple (* Note 3)		T type thermocouple (* Note 3)			
		No averaging (* Note 1)	With averaging (* Note 2)	No averaging (* Note 1)	With averaging (* Note 2)	Temperature of terminal to 1000 °C	-100 °C to temperature of terminal	Temperature of terminal to 750 °C	-100 °C to temperature of terminal	Temperature of terminal to 350 °C	-100 °C to temperature of terminal	
Analog output range switching	4	0 to 20mA	- 10 to +10V									

Notes

- (*1): No averaging: Conversion data is set for the specified input contact point area for each A/D conversion, on each channel.
- (*2): With averaging: On each channel, for each A/D conversion, the maximum and minimum values from the data of the last ten times are excluded, and the data from the other eight times is averaged, and the result set. (* section 7.1)
- (*3): If a thermocouple setting is used, averaging is carried out, regardless of the switch settings. (* section 7.2)

1.2 Analog I/O Terminal

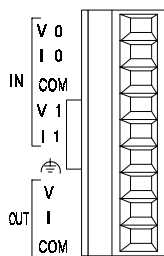

Pin number	Name	Description
1	IN/V 0	Analog input (channel 0), voltage input
2	IN/I 0	Analog input (channel 0), current input
3	IN/COM	Analog input (channel 0 and 1), analog input common
4	IN/V 1	Analog input (channel 1), voltage input
5	IN/I 1	Analog input (channel 1), current input
6		Ground for analog cable
7	OUT/V	Voltage output
8	OUT/I	Current output
9	OUT/COM	Analog output common

2 Specifications

2.1 General Specifications

Item	Description
Rated operation voltage	24 V DC
Operating voltage range	21.6 to 26.4 V DC
Rated current consumption	100 mA or less (*see FP0 User's Manual)
Allowed momentary power off time	10 ms
Ambient temperature	0 °C to +55 °C/32 °F to +131 °F
Storage temperature	-20 °C to +70 °C/-4 °F to +158 °F
Ambient humidity	30% to 85% RH (non-condensing)
Storage humidity	30% to 85% RH (non-condensing)
Breakdown voltage	500 V AC for 1 minute between I/O terminal and power supply/ground terminal 500 V AC for 1 minute between input and output terminals
Insulation resistance	min. 100 MΩ (measured with a 500 V DC megger) for between I/O terminal and power supply/ground terminal min. 100 MΩ (measured with a 500 V DC megger) for between input and output terminals
Vibration resistance	10 Hz to 55 Hz, 1 cycle/min: double amplitude of 0.75 mm/0.030 in., 10 min on 3 axes
Shock resistance	Shock of 98 m/s ² or more, 4 times on axes
Noise immunity	1,000 Vp-p with pulse widths 50 ns and 1μs (based on in-house measurements)
Operating condition	Free from corrosive gases and excessive dust

2.1.1 Weight

Type	Weight
A21	approx. 100 g/3.53 oz

2 Specifications

2.2 Analog Input Specifications

Item	Description		
Number of input points	2 channels/unit		
Input range	Voltage range	0 to 5 V/- 10 to +10 V	
	Current range	0 to 20 mA	
	Thermocouple range	K, J and T type thermocouples	
Digital output	0 to 5 V/ 0 to 20 mA		
	- 10 to +10 V		
	Thermo-couple (units in °C)	K type	K (temperature of terminal) to K1000 (* Note 1) K - 100 to K (temperature of terminal) (* Note 2)
		J type	K (temperature of terminal) to K750 (* Note 1) K - 100 to K (temperature of terminal) (* Note 2)
		T type	K (temperature of terminal) to K350 (* Note 1) K - 100 to K (temperature of terminal) (* Note 2)
When disconnected: K 20000			
Resolution	1/4000		
Conversion speed	Voltage/ current range Voltage/ current range	1 ms/channel (*Note 3)	
	Thermocouple range	560 ms (fixed)	
Overall precision	Voltage/ current range Voltage/ current range	± 1% F.S. or less (0 to 55 °C/32 to 131 ° F) ± 0.6% F.S. or less (25 °C/77 ° F)	
	Thermocouple range	Offset error (0 to 55 °C/32 to 131 F°): ± 2 % F.S. or less (K type thermocouple) (* Note 4) ± 2.7 % F.S. or less (J type thermocouple) (* Note 4) ± 5.8 % F.S. or less (T type thermocouple) (* Note 4) Linearity error: ± 1 % F.S. or less(0 to 55 °C/32 to 131 ° F)	
Input impedance	Voltage range	1 MΩ or more	
	Current range	250Ω	
Absolute maximum input	Voltage range	±15 V	
	Current range	+30 mA	
Insulation method (*Note 5)	Between analog input terminal to FP0 internal circuit: photocoupler insulation (non-insulated between analog inputs) Between analog input terminal to analog I/O unit external power supply: insulation-type DC/DC converter Between analog input terminal to analog output terminal: insulation-type DC/DC converter		
Number of input contact points	32 input contact points: 16 points for 1st half: analog input CH0 data (WX2) (* Note 6) 16 points for last half: analog input CH1 data (WX3) (* Note 6)		

. next page

Notes

- (*1): The temperature lower than the temperature of terminal of the analog I/O unit cannot be measured.
- (*2): The temperature higher than the temperature of terminal of the analog I/O unit cannot be measured.
- (*3): The time noted below is required before the analog data is reflected in the control unit input.

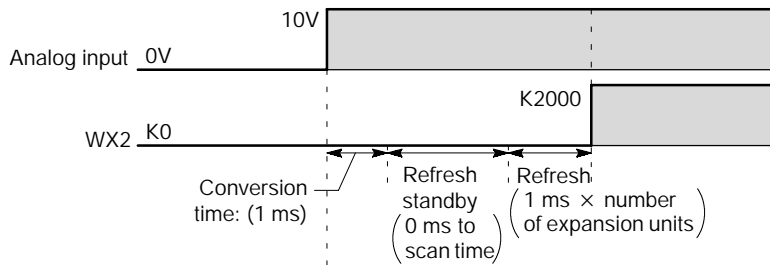

- (*4): Refer to the *section 6 "Boosting the Precision of the Thermocouple Range."
- (*5): Refer to the schematic diagram of insulation methods below.

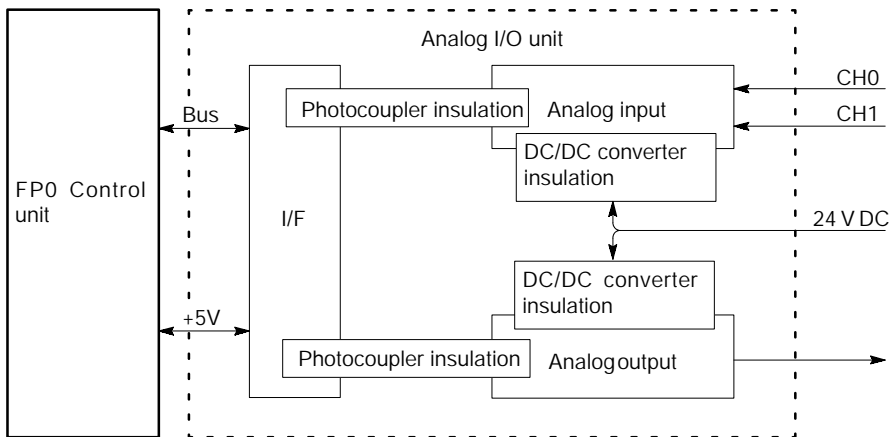

- (*6): The number for the input contact point being used varies depending on the expansion location.

	I/O number		
	First expansion	Second expansion	Third expansion
Input channel 0: 16 points	WX2 (X20 to X2F)	WX4 (X40 to X4F)	WX6 (X60 to X6F)
Input channel 1: 16 points	WX3 (X30 to X3F)	WX5 (X50 to X5F)	WX7 (X70 to X7F)
Output: 16 points	WY2 (Y20 to Y2F)	WY4 (Y40 to Y4F)	WY6 (Y60 to Y6F)

2 Specifications

2.3 Analog Output Specifications

Item		Description
Number of output points		1 channel/unit
Output range	Voltage range	-10 to +10 V
	Current range	0 to 20 mA
Digital input	-10 to +10 V	K - 2000 to K + 2000 (HF830 to H07D0)
	0 to 20 mA	K0 to K4000 (H0 to H0FA0)
Resolution		1/4000
Conversion speed		500 μ S (* Note 1)
Overall precision		\pm 1% F.S. or less (0 to 55 °C/32 to 131 ° F) \pm 0.6% F.S. or less (25 °C/77 ° F)
Output impedance	Voltage range	0.5 Ω
Maximum output current	Voltage range	\pm 10 mA
Allowable output load resistance	Current range	300 Ω or less
Insulation method (* Note 2)		Between analog output terminal to FP0 internal circuit: Photocoupler insulation Between analog output terminal to analog I/O unit external power supply: insulation-type DC/DC converter Between analog output terminal to analog input terminal: insulation-type DC/DC converter
Number of output contact points		16 output contact points: analog output data (WY2) (* Note 3)

Notes

- (*1): The time noted below is required before the analog data is reflected in the control unit output.

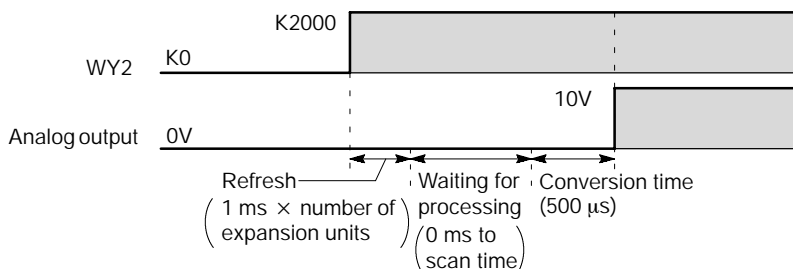

- (*2): Refer to the schematic diagram of insulation methods on the previous page.
- (*3): The number for the output contact point being used varies depending on the expansion location (See 2.2 Analog Input Specifications Note *6).

3 A/D Conversion Characteristics

Current range: 0 to 20 mA DC input

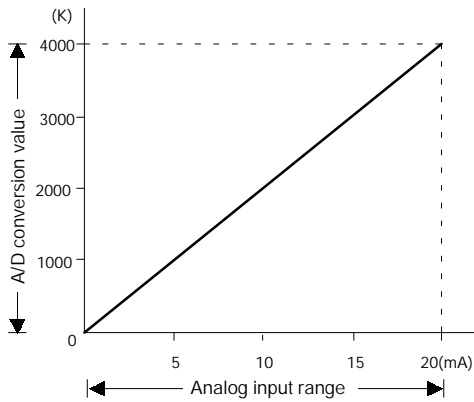

Correspondence table of A/D conversion values

Input current (mA)	A/D conversion value
0.0	0
2.5	500
5.0	1000
7.5	1500
10.0	2000
12.5	2500
15.0	3000
17.5	3500
20.0	4000

Processing if the range is exceeded

Input value	Converted value
0 mA or less (including negative value)	0
20 mA or more	4000

Voltage range: 0 to 5 V DC input

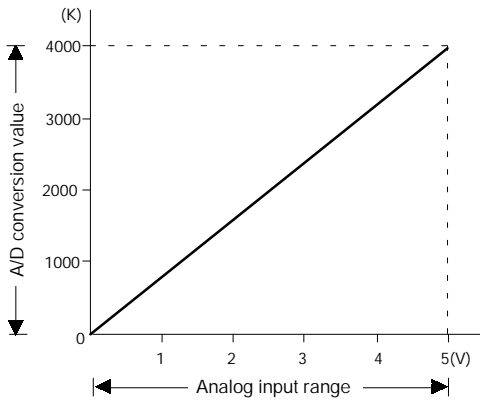

Correspondence table of A/D conversion values

Input voltage (V)	A/D conversion value
0.0	0
0.5	400
1.0	800
1.5	1200
2.0	1600
2.5	2000
3.0	2400
3.5	2800
4.0	3200
4.5	3600
5.0	4000

Processing if the range is exceeded

Input value	Converted value
0 V or less (including negative value)	0
5 V or more	4000

3 A/D Conversion Characteristics

Voltage range: -10 to +10 V DC input

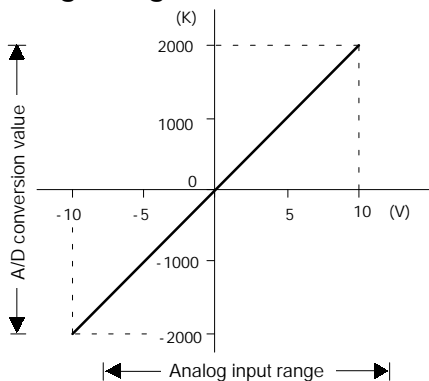

Correspondence table of A/D conversion values

Input voltage (V)	A/D conversion value
-10.0	-2000
-7.5	-1500
-5.0	-1000
-2.5	-500
0.0	0
+2.5	+500
+5.0	+1000
+7.5	+1500
+10.0	+2000

Processing if the range is exceeded

Input value	Converted value
-10 V or less	-2000
+10 V or more	+2000

Thermocouple input:

Setting a temperature higher than the temperature of terminal using the analog mode switch (*section 1.1)

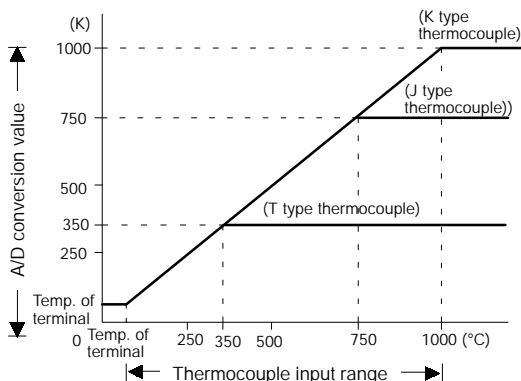

Correspondence table of A/D conversion values

Temperature (°C)	A/D conversion value
Temperature of terminal	Temperature of terminal
25	25
250	250
350	350
500	500
750	750
1000	1000

Processing if the range is exceeded

Input value	Converted value	
Temperature of terminal or less	Temperature of terminal	
Upper limit	350 °C or more (with T type thermocouple)	350
	750 °C or more (with J type thermocouple)	750
	1000 °C or more (with K type thermocouple)	1000
Disconnected	20000	

If the measured temperature exceeds the upper limit of the range, a value higher than the upper limit value is not output.

Thermocouple input:

Setting a temperature lower than the temperature of terminal using the analog mode switch (*section 1.1)

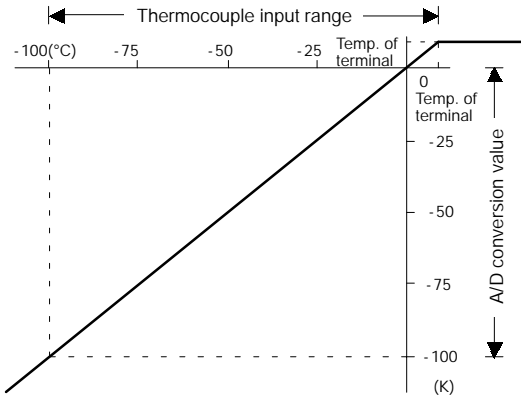
**Correspondence table of A/D conversion values**

Temperature (°C)	A/D conversion value
Temperature of terminal	Temperature of terminal
0	0
-25	-25
-50	-50
-75	-75
-100	-100

Processing if the range is exceeded

Input value		Converted value
Temperature of terminal or more		Temperature of terminal
Lower limit	with T type thermocouple	-250
	with J type thermocouple	-200
	with K type thermocouple	-250
Disconnected		20000

A value is output even if the boundary of the measured value (-100 °C) is exceeded, but the measurement accuracy cannot be guaranteed.

4 D/A Conversion Characteristics

Voltage range: -10 to +10 V DC output

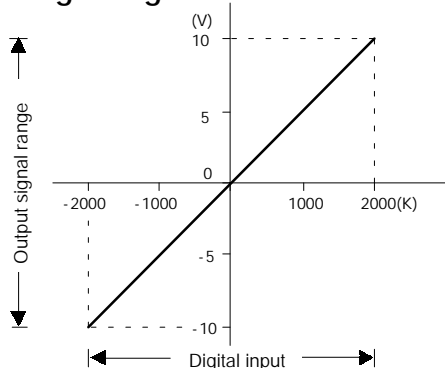

Correspondence table of D/A conversion values

Digital input value	Output voltage (V)
-2000	-10.0
-1500	-7.5
-1000	-5.0
-500	-2.5
0	0.0
+500	+2.5
+1000	+5.0
+1500	+7.5
+2000	10.0

Processing if the range is exceeded

Digital input value	Analog output value
-2001 or less	Constant (value just before -2001 is input)
+2001 or more	Constant (value just before +2001 is input)

Current range: 0 to 20 mA output

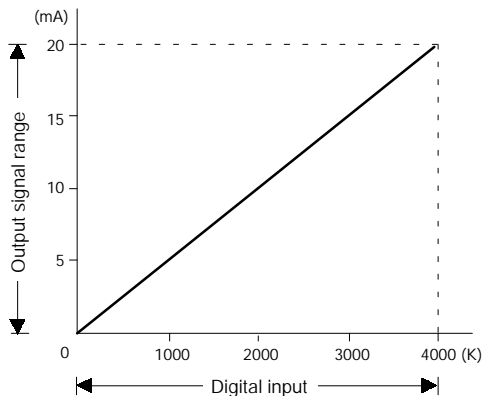

Correspondence table of D/A conversion values

Digital input value	Output current (mA)
0	0.0
500	2.5
1000	5.0
1500	7.5
2000	10.0
2500	12.5
3000	15.0
3500	17.5
4000	20.0

Processing if the range is exceeded

Digital input value	Analog output value
Negative value	Constant (value just before negative value is input)
4001 or more	Constant (value just before 4001 is input)

5 Wiring

5.1 Analog Input Wiring

Voltage input

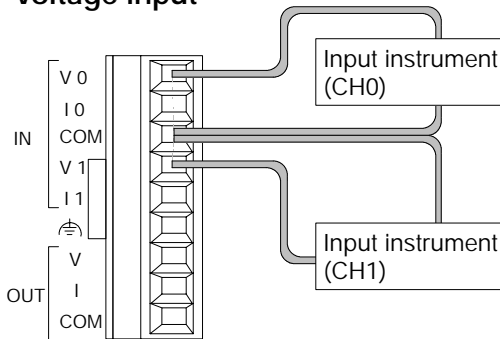

Connect input instrument between IN/V and IN/COM terminal.

Current input

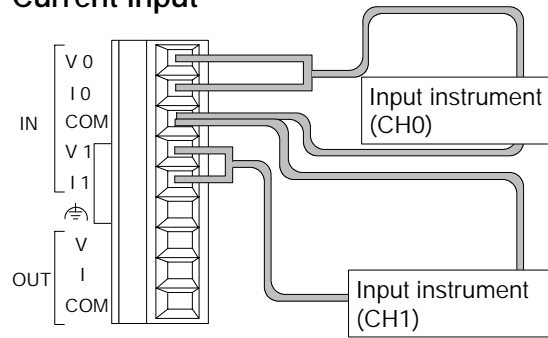

First, connect both IN/V terminal and IN/I terminal. And then connect input instrument between it and IN/COM terminal.

Thermocouple input

(when measured at temperature higher than the temperature of terminal)

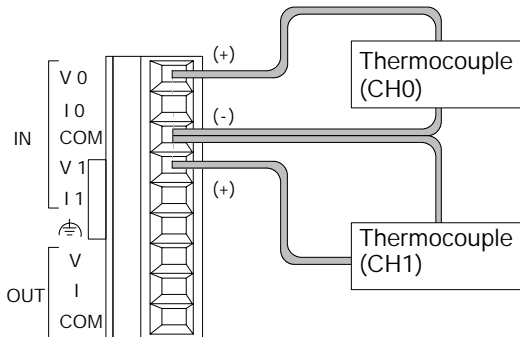

Connect IN/V terminal to the (+) side of the thermocouple, and connect IN/COM terminal to the (-) side of the thermocouple.

Thermocouple input

(when measured at temperature lower than the temperature of terminal)

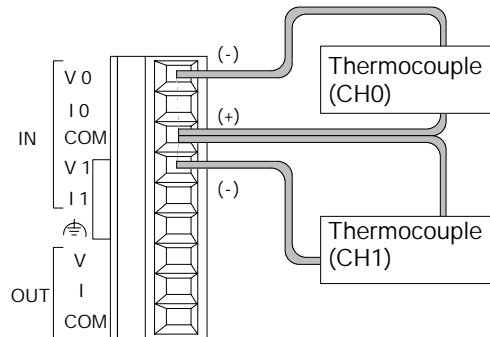

Connect IN/V terminal to the (-) side of the thermocouple, and connect IN/COM terminal to the (+) side of the thermocouple.

5.2 Analog Output Wiring

Voltage output

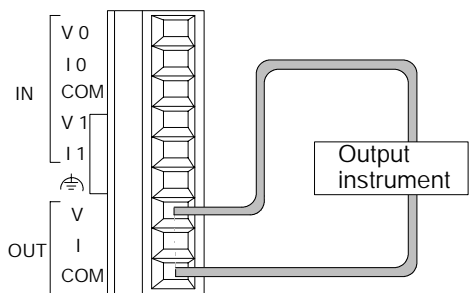

Connect output instrument between OUT/V and OUT/COM terminal.

Current output

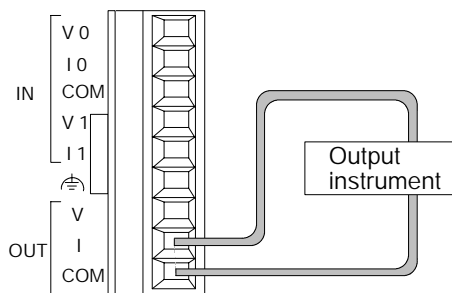

Connect output instrument between OUT/I and OUT/COM terminal.

Notes

- Always make sure the switch settings and the terminal base wiring connections match. For output, in particular, if the settings and the wiring connections are wrong, the control unit will output values like those shown below, even in the PROG. mode. (For information on switch settings, see * section 1.1.)

Item	Output terminal (OUT)	
	Current terminal (I)	Voltage terminal (V)
0 mA output based on current range setting	0 mA	-10 V
0 V output based on voltage range setting	10 mA	0 V

- DA internal block diagram
A voltage amplifier and current amplifier are connected in parallel to a single DA converter IC.

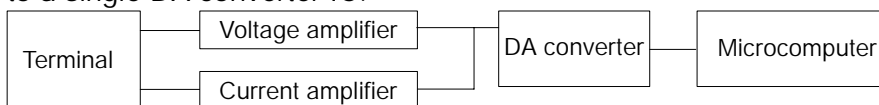

Also, the digital value that is sent to the DA converter IC to achieve a voltage output of 0 V is different from that input to the DA converter IC to achieve a current output of 0 mA.

As a result, if the voltage output is set to 0 V, 10 mA is output from the current output terminal, and conversely, if the current output is set to 0 mA, -10 V is output from the voltage output terminal (see tables the next page).

next page

- For voltage output

Value of WY	K - 2000	K0	K2000
Digital value to DA converter	0	2047	4095
Analog output	-10 V	0 V	+10 V

- For current output

Value of WY	K0	K2000	K4000
Digital value to DA converter	0	2047	4095
Analog output	0 mA	10 mA	20 mA

7 Averaging Function

7.1 Averaging for Voltage Ranges and Current Ranges

When the input range is set to a voltage range or current range, processing like that shown below is carried out internally of analog I/O unit.

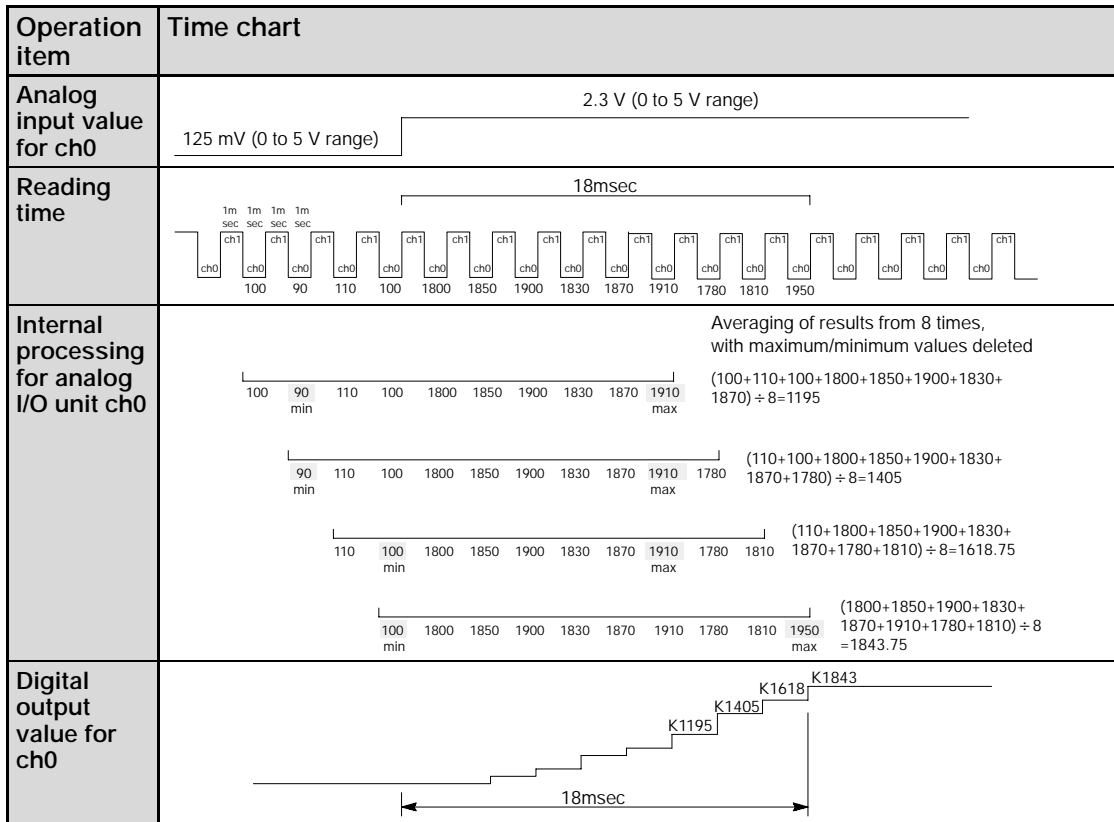

Starting from the most recent data, the data from the last ten times is taken. The maximum and minimum values are deleted, and then averaging is carried out on the remaining eight items. The value obtained from the most recent averaging is normally used as the value output at this time. (If a fraction results from the calculation, it is rounded off.)

7.2 Averaging for a Thermocouple Range

When the input range is set to a thermocouple (K, J or T type), processing like that shown below is carried out internally in the analog I/O unit.

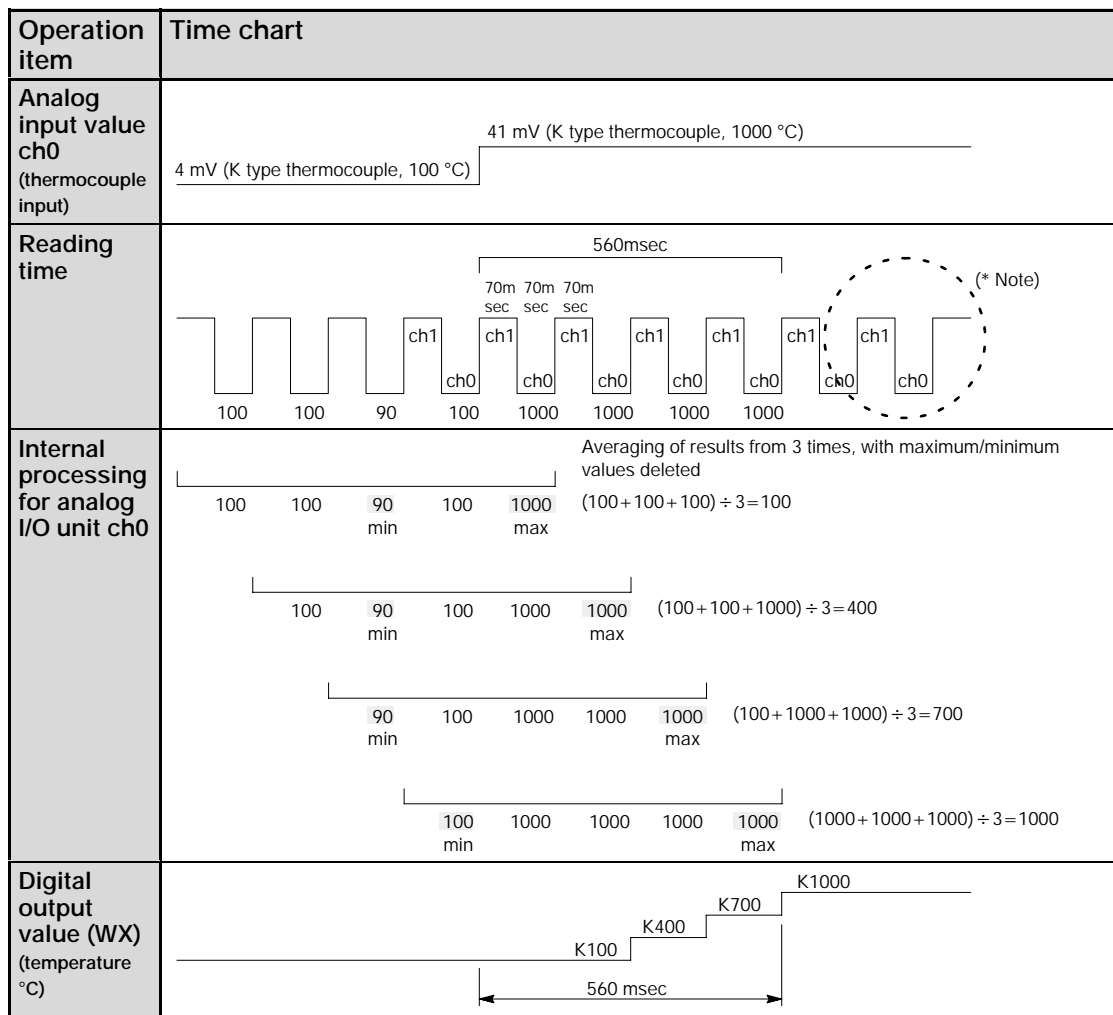

Starting from the most recent data, the data from the last five times is taken. The maximum and minimum values are deleted, and then averaging is carried out on the remaining three items. The value obtained from the most recent averaging is normally used as the value output at this time. (If a fraction results from the calculation, it is rounded off.)

Note

In the read timing, the minimum and maximum values are subtracted from the data from the last ten times, just as in averaging processing of section 7.1, and the data from the remaining eight times is used for the averaging.

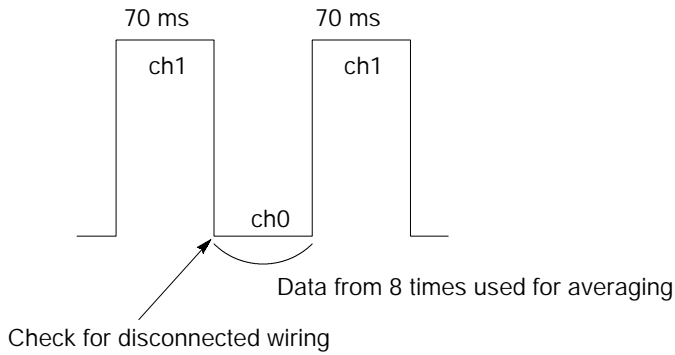

If a disconnected wire is detected, a value of K20000 is output.

8 Analog I/O Unit Programs

The data transmission instruction **F0 (MV)** is used to read data from the analog I/O unit, and to write it to the unit.

Analog input

Program example

Digital values which have been converted in the analog I/O unit are stored in any desired data register.

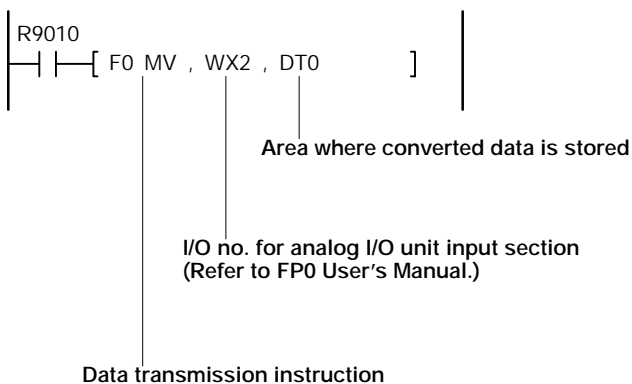

If "0 to 20 mA DC input" has been specified for the input range in the above program, the values of K0 to 4000 are stored in DT0.

Configuration diagram

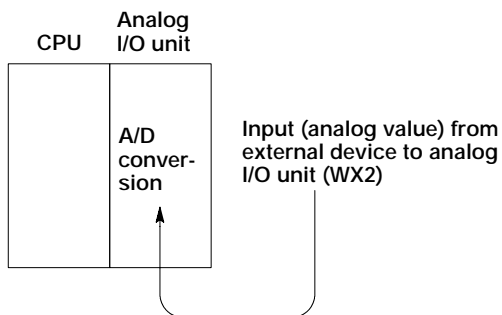

Analog output

Program example

Digital values which have been stored in any desired data register are transferred to the analog output area.

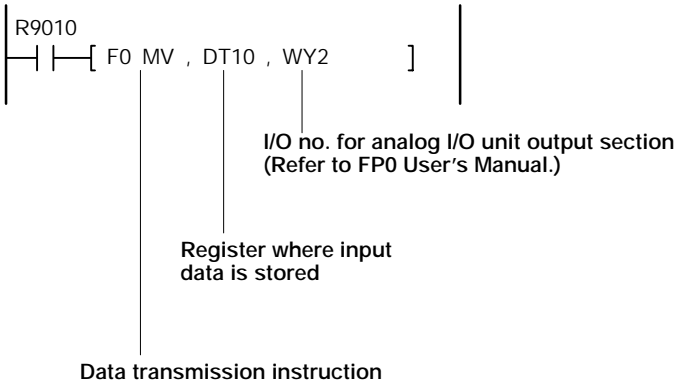

If "0 to 20 mA DC output" has been specified for the output range in the above program, writing data of range of K0 to 4000 to DT10 causes 0 to 20 mA DC to be output from the analog I/O unit.

Configuration diagram

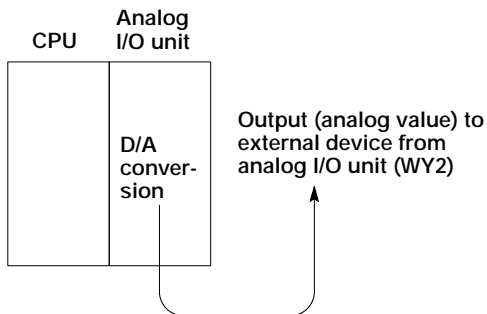

Precautions during programming

The I/O numbers for the specified analog I/O unit input and output sections vary depending on the installed position of the analog I/O unit. Refer to the FP0 User's Manual for the I/O numbers.

Data values undergoing A/D and D/A conversion vary depending on the range used. Refer to the "FP0 User's manual" for the range.

9 Dimension

Analog I/O Unit FP0 - A21 (AFP0480)

(Unit: mm)

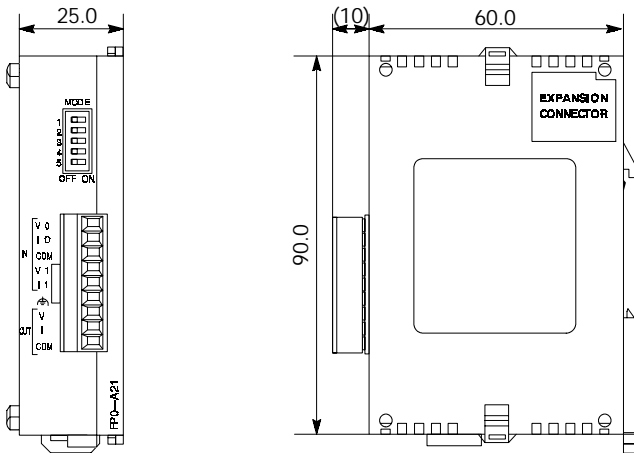

Record of changes

ACG No.	Date	Description of Changes
ARCT1F390E	FEB. 2004	First edition - This manual was transferred from the FP0 hardware manual (ACG-M0084-3).



These materials are printed on ECF pulp.
These materials are printed with earth-friendly vegetable-based (soybean oil) ink.



Please contact

Matsushita Electric Works, Ltd.

Automation Controls Company

■ Head Office: 1048, Kadoma, Kadoma-shi, Osaka 571-8686, Japan

■ Telephone: +81-6-6908-1050

■ Facsimile: +81-6-6908-5781

<http://www.nais-e.com/>

All Rights Reserved © 2006 COPYRIGHT Matsushita Electric Works, Ltd.