

X3M 96

Energy Data Manager

X3M 96 H

Energy & Harmonics Data Manager



- u The **X3M** performance
- u The **X3M** versatility
- u The **X3M** reliability

The X3M 96 is a microprocessor based Energy Data Manager with outstanding flexibility and accuracy designed to meet the most demanding applications of electrical parameters analyses and energy supply monitoring in the industrial environment.

All the readings are "true-RMS" and they are obtained with a continuous sampling of the voltage and current waveforms in order to ensure the maximum metering accuracy of rapidly varying loads (e.g. spot welding) as well as the instrument's suitability for energy quality supervision functions. A patented digital measurement system, an automatic scale change on current inputs and a compensation system of the internal amplifiers' offsets ensure the maximum metering accuracy and stability irrespective of the signal level and the environmental working conditions.

The X3M 96 is equipped with a high capacity flash memory for the storage of data of the load profiles analyses as well for the recording of events related to the quality of the electrical energy supply per EN50160 standards.

The X3M 96 is a revolutionary instrument that may be upgraded after installation for new user needs and to its installation parameters. Two expansion ports make it possible to select the data transmission mode by means of a simple connection of optional modules (RS232, RS485, Analog, I/O) while the instrument architecture is designed to enable the implementation, in the field, at any time, of firmware modifications by means of program up-loads with the purpose of expanding and/or replacing the existing functions with new and different ones.

Simple to use

A large high-contrast LCD display with white led backlight allows the simultaneous reading of 4 parameters and their symbols with high visibility digits. A bar-graph indicator supplements the reading mode of 3 parameters in analogue format also.

9 keys, with clear indication of their function, make the instrument use simple and intuitive.

A Led indicator, pulsing with a frequency proportional to the active import power, is also provided on the front panel for field calibration verification by means of external optical devices.



Versatile in application

The X3M 96 is suitable for virtually all type of electrical grid, 3- and 4-wire, symmetrical and asymmetrical, balanced or unbalanced, single- and bi-phase, Low Tension and High Tension, with 1, 2 or 3 CTs as well as for 2 and 4 quadrant (import/export) measurement.

A simple keyboard programming allows the setting of all the operational parameters such as grid type, LV/HV, CT and VT ratios (free setting) integration time (1-60 min), alarms (thresholds, delays, hysteresis), digital outputs and configuration of the optional modules that may be connected.

(1) Mean value (rolling average) over the integration time (1.. 60 min. programmable)
(2) Energies displayed as 6 digit floating-point readings: internal energy metering performed with 0,1 Wh minimum resolution and 99.999.999.999 kWh maximum energy count before rollover.

Display Readings

Parameter	Type	L1	L2	L3	Σ	Range
Voltage	V L-N	h	h	h	h	20,0V...400 kV
	V L-L	h	h	h	h	
Current	I-phase	h	h	h	h	10 mA...10,0 kA
	I-neutral				h	
Power Factor	PF	h	h	h	h	0,00ind...1,00...0,00cap
Frequency	Hz				h	45 ... 65 Hz
Harmonic distort.	THD-V	h	h	h	h	0...199,9%
	THD-I	h	h	h	h	
Life time	h (1/100 h)				h	0,01...99.999,99 hours
Active power	P	h	h	h	h	± 0,00...1999 MW
	Pm (°)				h	
	Pmd (°)				h	
Reactive power	Q	h	h	h	h	± 0,00...1999 Mvar
	Qm-ind (°)				h	
	Qm-cap (°)				h	
	Qmd-ind (°)				h	
	Qmd-cap (°)				h	
Apparent power	S	h	h	h	h	± 0,00...1999 MVA
	Sm (°)				h	
Active energy	KWh (°)				h	0,1 kWh...99.999,9 MWh
Reactive energy	Kvarh-ind (°)				h	0,1 kvarh...99.999,9 Mvarh
	Kvarh-cap (°)				h	
Apparent energy	KVAh (°)				h	0,1kVAh...99.999,9 MVAh

X3M 96 with FFT harmonics option or X3M 96 H

FFT Harmonics	H Voltage	h	h	h		Value (H01), % (H02-H31)
	H Current	h	h	h		Value (H01), % (H02-H31)
	H Power & dir.	h	h	h		Value (H01), % (H02-H31)

Power quality (EN 50160)

Parameter	L1	L2	L3	Σ	Handling
Sags, swells/dips	h	h	h		Event logging to built-in memory with date time stamp
Over-U, Over-I,	h	h	h		
Under-U, Mains interruption	h	h	h		
Min/Max values	h	h	h		

Alarms

The X3M 96 is equipped with 2 programmable alarms offering the maximum configuration flexibility for adapting to the most diverse requirements.

Each alarm can be selected to link to any one of the parameters available, either as a minimum or as a maximum alarm. Linking of both alarms to the same parameter is also possible for operating as dual threshold alarm.

Special alarms are also available such as min. or max. voltage and max. current applicable to the 3 phases and current unbalance on the 3 phases.

The alarms configuration includes the option of precise setting of a delay time (1-99 sec), an hysteresis cycle (in %) and the activation of the output contacts.

The alarms state information is always available on serial communication as Modbus "coils".

The alarms are entirely programmable by keyboard and via serial port with the Energy Brain software or by means of Modbus Holding registers.

Digital outputs

The X3M 96 is equipped, as standard feature, with two optically isolated transistor outputs rated 27 Vdc 27 mA per DIN 43864 standards.

The two outputs are factory set to the transmission of pulses proportional to the Active energy and the Reactive energy: the pulse number and rate are user programmable.

The outputs may be alternatively configured as outputs of the internal alarms or as remote output devices controlled via serial line and Modbus commands.

Serial communication

The X3M 96 supports an RS485 or RS232 serial communication by means of optional add-on modules.

The protocol is the Modbus RTU or ASCII, suitable for communication with PLCs and with SCADA programs. The X3M 96 protocol provides as well "full compliance" with the Modbus and with its default configurations.

The instrument data are read as numerical registers composed by mantissa and exponent in the IEEE format.

A transmission speed of up to 38400 bps, with maximum 125 registers (equivalent to 62 parameters) per query with no waiting time between queries, ensure an unrivalled communication speed and dialogue efficiency.

Calendar/clock

The X3M 96 is equipped with a real-time calendar clock supporting the time zone (GMT + DST) format and the rules for the automatic switching from Standard Time to Daylight Saving Time and vice versa.



Real time calendar clock with battery buffer (20 years duration)

TOU tariffs

The X3M 96 is designed to handle the most complex TOU systems, with up to 8 different tariffs with a maximum of 12 tariff changes per day.

The readings supplied encompass the energy consumptions (Ea, Er, Es) and the Maximum Demand (Pmd, Qmd, Smd) on the 4 quadrants, total values and distinct values for each of the 8 tariffs for a total of 64 energy counters and 64 Maximum Demand values. In the case of Import (2 quadrant) measurement and with a lower number of tariffs, the applicable counters only are updated.

All the readings related to each tariff are available on display and on serial communication.

For proper handling of TOU tariff systems, the X3M 96 requires the up-load of a specific calendar file that may be generated by means of the Energy Brain or edited by the user in binary mode following the specifications.

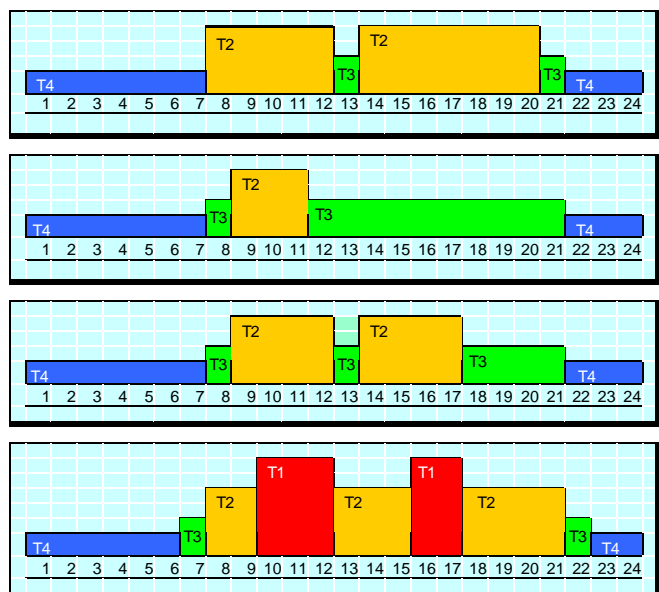

Example of 4-tariff system

Data Storage Memory

The X3M 96 is equipped with a 2 MB flash disk memory for the storage of numerous data and events. The large memory capacity supports the storage of up to 60 days' load profiles (with 15 min. samples) or over 50.000 logs as well as other repartition according to the type of events. The memory is structured with the file system and the data is saved as distinct files, organized by type of services.

POWER QUALITY EVENTS (EN 50160 standards)

The X3M 96 detects and stores, with individual date-time stamp several events giving an accurate monitoring of the power supply quality according to the EN 50160 standards.

- **Voltage sags/dips**
- **Temporary over voltage/swell**
- **Temporary current peak and direction of flow**

i.e. short duration events (1 cycle resolution) with registration of date-time, event type, phase involved, duration in number of cycles and min/max parameter value attained during each event. Example:

Date	Time (*)	Event type	Duration (Cycles)	Min/Max Value
20 Dec. 06	16.35.30.67	Voltage Sag V1N	10	21,25
12 Feb. 06	16.35.15.21	Voltage Sag V2N	30	66,32
16 Feb. 06	16.35.32.20	Voltage Swell V3N	25	273,12
16 Feb. 06	16.39.58.87	Import Current Peak I2	5	152,51
16 Feb. 06	16.41.30.91	Import Current Peak I3	7	163,56
16 Feb. 06	16.41.45.07	Import Current Peak I1	3	155,83

- **Under voltage/voltage interruption**
- **Over voltage**
- **Over current and direction of flow**

i.e. medium and long duration events with registration of event start-end date/time, event type, phase involved and parameter min/max value attained during each event. Example:

Date	Time(*)	Event type	Min/Max Value
19 Jan. 06	15.59.02.17	Under voltage Start V3N	-
19 Jan. 06	15.59.17.31	Under voltage End V3N	20,48
20 Feb 06	16.37.46.49	Under voltage start V1N	-
20 Feb. 06	16.41.45.88	Under voltage End V1N	60,34
01 Mar. 06	16.08.19.27	Over voltage Start V2N	-
01 Mar. 06	16.08.19.99	Over voltage End V2N	264,35
01 Mar. 06	16.02.29.23	Import over current Start I1	-
01 Mar. 06	16.08.19.72	Import over current End I1	213,74

Discrimination of the event type is programmable for each parameter in terms of duration (no. of cycles, trigger-on value and trigger-off value).

Instrument power supply interruptions are also logged in order to provide a complete picture of the activities.

16 Jan. 06	16.34.49.88	Power OFF
16 Jan. 06	16.35.03.50	Power ON
16 Jan. 06	16.35.04.10	Events Detection Enable

MIN. AND MAX. VALUE LOGS

The X3M 96 records the absolute minimum and/or maximum instantaneous value (RMS over 1 sec) attained by the most significant parameters and logs the event in memory with date and time stamp.

- Voltage minimum and maximum value per phase
- Currentmaximum value per phase
- Active and Apparent powermaximum value per phase
- Power factorminimum value per phase

(*) all time stamps in hours, minutes, seconds and seconds/100.

LOAD PROFILES AND CONSUMPTION DATA

The X3M 96 systematically stores the consumption and demand data into *day files* containing all the necessary information for drawing accurate load profiles and also for comprehensive consumption analyses over long periods.

- Daily load profiles on the 4 quadrants with sampling according to the integration period. Up to 60 days' data default capacity with 15 min. samples.
- Max. Demand on the 4 quadrants and for each tariff, where programmed.
- Energy consumption on the 4 quadrants and for each tariff, where programmed.

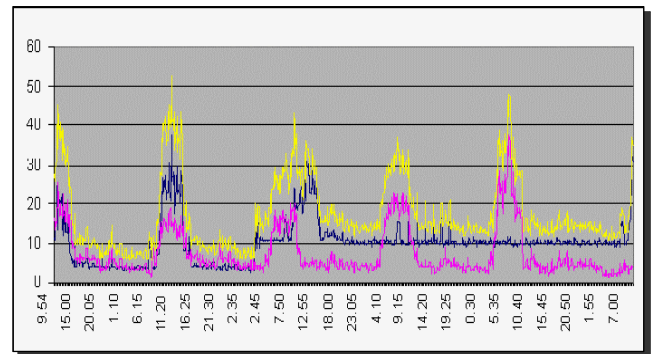

HARMONICS SURVEYS (with FFT option only)

Harmonic Surveys can be made when the FFT upgrade is installed on the instruments. A date/time stamped sample of 42 default readings is automatically saved to the instruments' built-in memory on a circular buffer (FIFO) covering a 10-day survey period with samples taken every 2 minutes and data organised in daily files.

FUNCTIONAL LOGS

The memory is also used for several additional operations such as:

- Functional logs tracking all the operations that introduce a settings change of the instrument since initial install.
- TOU calendar files for the handling of TOU tariffs and other memory configuration files.
- Specific files for special programming and/or for future implementation of new functions by means of up-loads.

As a consequence of the large amount and complexity of the data collected in the memory, the configuration of the various memory services and the data downloads are exploited via serial port. The Energy Brain software represents an easy all-users tool. The use of the "read general file" and "write general file" Modbus commands is otherwise available.

System integrators and expert users are given the additional possibility of developing and configuring new customised data handling services thanks to the great flexibility of the memory architecture and of the data storage organisation. Specialised technical literature is available separately.

Open architecture

The X3M 96 is a revolutionary instrument in its kind, because it may be easily adapted to follow the user needs at any time after its installation. The instrument architecture is designed for field implementation of hardware and firmware expansions for the support of new functions. The benefit for the user is the possibility of spreading the initial investment and, most of all, the confidence of an instrument that will allow, at any time, new and unanticipated technical requirement.



HARDWARE EXPANSIONS (optional modules)

The X3M 96 is fitted with 2 expansion sockets for the connection of external expansion modules supporting specific communication functions (serial, analogue, digital, I/O). Connection of the optional modules to the instrument is simply made by attached cable with RJ45 plug. The optional modules are self-supplied and the applicable programming menu is automatically enabled by the instrument upon connection of the option(s).

FIRMWARE EXPANSIONS (options/uploads)

The instrument architecture is designed to deal with modification of the instrument operative firmware for the purpose of integrating the existing characteristics with new and different functions (example, harmonics analyses, special applications, special data storage configurations, etc.) The functions enhancement may be carried out by means of simple key code entries (for functions that are already embedded), with file up-loads via the Energy Brain software (for networked instruments) or with special upgrade programs supplied by Electrex where required.

HARDWARE EXPANSIONS (optional modules)

- Option module 96 RS485

Opto isolated RS485 port with 2400 bps to 38400 bps. programmable speed. It supports instrument networking with other units up to a distance of 1000 meters and up to max 128 meters connected on the same communication pair with no need of additional line amplifiers.



- Optional module 96 RS232

Opto isolated RS232 port with 2400 bps to 38400 bps programmable speed. 9-pole (D-sub9 female) connector.



- Option module 96 2AO4-20 mA

2 galvanically isolated analogue outputs; 4-20 mA or 0-20 mA transmission. Extremely high accuracy and signal stability thanks to a 10 bit digital to analogue conversion that maintains the accuracy of the original parameter. It ensures a response time of max. 50 ms. with max. 200 ms. update interval. Each of the two outputs may be linked to any one of the parameters available with the additional possibility of setting the zero output (4 or 0 mA) and/or the 20 mA output to match any desired positive or negative measurement value.



- Option module 96 2DI 2DO

Module for the acquisition of the ON-OFF state of external contacts (example: MCBs, switches, auxiliary contacts, etc.). It features 2 opto isolated inputs and 2 relay outputs with changeover contacts rated 30V 2A (resistive load) that may be used as remote output devices or as additional output contacts for the internal alarms. The inputs and outputs state is handled exclusively via serial port and Modbus commands and no user setting is available on display.



Technical specification

- Add-on modules
- Compact and lightweight
- Fixing to instrument rear panel
- No power supply required
- Connection:
 - Input: plug-in cable + connector
 - Output(s): plug-in terminal board 9-pole (D-sub9) for RS232
- Weight: max. 45 gr.
- Size: 60 x 40 x 20 mm.
- Suiting other Electrex panel meters

FFT HARMONICS ANALYSES (option)

The X3M 96 instruments feature the option of expanding their measurement capability by adding on new parameters to the existing ones. The FFT harmonics option adds all the parameters necessary for a comprehensive Harmonics analyses. It supports a 32 bit calculation which gives superior metering accuracy and to classify these instruments as genuine Energy & Harmonics analysers with a performance comparable with many sophisticated and expensive analysers.

General features

The FFT harmonics option supports all the readings that are needed for a superior analyses of the problems related to harmonics. Readings give both the harmonics power and the direction providing an invaluable tool for immediate examination of the harmonics flow inside one's own plant and for identifying potentially undesirable imported problems.

The FFT harmonics option can be implemented on X3M 96 at any time, after instrument installation and requires no tools nor accessories. It is simply performed by the entry, via front keyboard, of a unique PUK code that may be ordered for the serial number of the instrument to be upgraded.

The FFT harmonics option may also be supplied in the meter by ordering the instrument type X3M-H with the option.

Harmonics surveys

With the X3M 96 instruments, Harmonic Surveys can be made when the FFT upgrade is installed.

A date/time stamped sample of 42 default readings is automatically saved to the instruments' built-in memory on a circular buffer (FIFO) covering a 10-day survey period with samples taken every 2 minutes. Each sample covers:

- Voltage: **U, THD-U, H1-U, H3-U, H5-U, H7-U** and **H9-U** per phase
- Current: **I, THD-I, H1-I, H3-I, H5-I, H7-I** and **H9-I** per phase

The survey data is retrieved via serial line as daily files in the HTML, XLS or TXT formats (line commands required).

Modbus communication

A total of 384 readings related to harmonics are enabled as Modbus registers on serial port by the FFT harmonics option.

- Current and voltage harmonics per order and per phase
- Phase angle in degrees (range -180,0÷180,0°) per harmonic order, per phase, referred to U_{L1} fundamental.

These parameters may be used for external reconstruction of vectorial graphs such as those supported by the Energy Brain software (v.4.0.0)

Technical specification

Harmonics range Odd and Even harmonics up to 31st order
Parameters... H_U, H_I, H_P & sign (direction) per order, per phase
Parameters up date interval..... approx. 1 s
Readings indication:

- H01 ..floating pnt. values with automatic unit/K/M exponent
- H02-31.. values in % of fund. (3½ digit, range 0,0÷100,0%)
- H direction(+) or (-) sign on power

Modbus readings:

Voltage, current , phase angle per harmonic order, per phase

Accuracy:

- H_U & H_I... ±(0,1%rdg.+1LSD) for H01 to max. ±2,0% for H31
- H_P ±(0,2%rdg.+2LSD) for H01 to max. ±2,0% for H31
- Phase angles ±0,1deg. for H01 to max ±3,0deg. for H31

Sampling frequency..... 64 x f (mains frequency)

FFT size 64 points

FFT calculation accuracy..... 32 bits

Window..... rectangular

Minimum reading 1%

Harmonics readings

• Voltages Harmonics

§ H01: value in V per phase

§ H02...31: value in % of the fundamental per phase

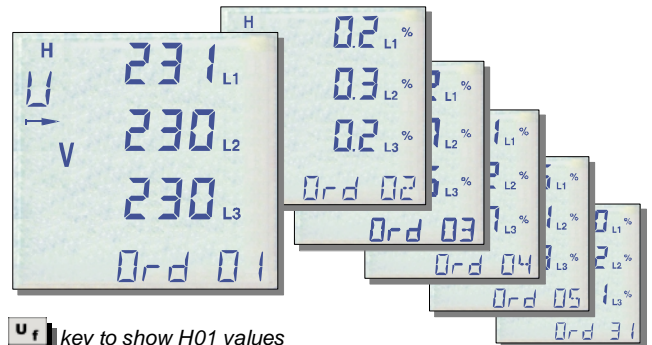

U key to show H01 values

▲ ▼ keys to scroll H02...H31 values

• Currents Harmonics

§ H01: value in A per phase

§ H02...31: value in % of the fundamental per phase

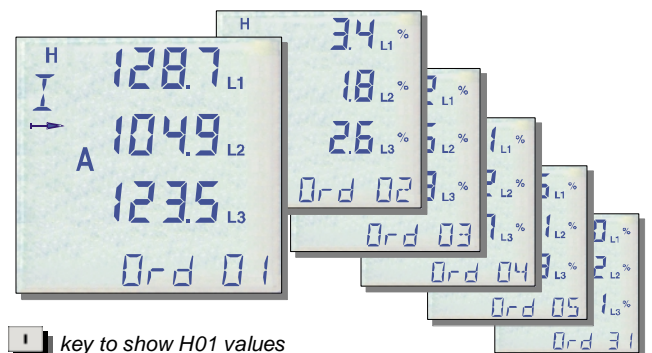

I key to show H01 values

▲ ▼ keys to scroll H02...H31 values

• Harmonics Powers/Direction

§ H01: value in W per phase

§ H02...31: value in % of the fundamental per phase

§ + or - sign indicating the harmonics origin downstream (load) or upstream (source) the measurement point.

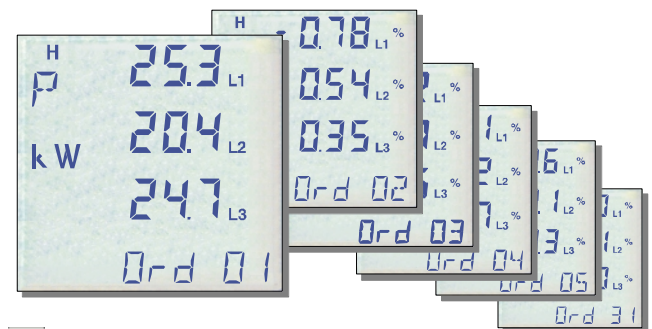

P key to show H01 values

▲ ▼ keys to scroll H02...H31 values

ENERGY BRAIN software

The Energy Brain is the software package designed for the realization of all types of local and/or wide area networks of instruments. It is suitable for application with all the Electrex instruments equipped with communication port and it supplies all the functions needed for an accurate monitoring and targeting of industrial energy consumption.

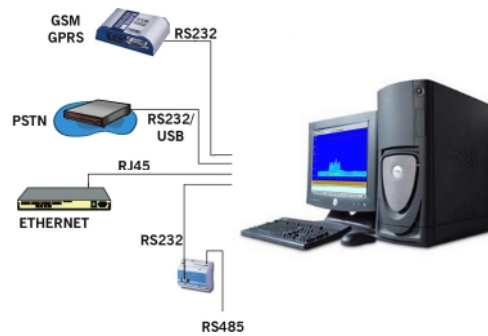

MAIN FUNCTIONS

Configuration

The available choices enable the maximum flexibility in adapting the software to the type of network (several types of simultaneously connected networks too) and to the operator needs.

- Field instruments set up (CT, PT, alarms, etc.)
- Network configuration (instrument, customer, groups, locations, etc) with individual setting of the communication mean local (by RS232/RS485, Ethernet) or remote (by Modem, GSM, Internet) and communication parameters (speed, etc.)
- Scheduling of the data collection and download agenda (distinct for location and customer) with daily, weekly or monthly intervals

Load and energy profiles/graphs

- Demand profiles (day, month and year)
- Energy profiles (day, month and year)
- Time-of-use Demand and Energy profiles
- MD profiles (per month, year and per tariff)
- Up to 4 graphs displayed simultaneously
- Zoom and parameter selection tools
- Graphical and numerical print-out

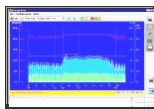

On line readings display

- On line display of the readings supplied by the field instruments.



Data collection and storage

- Automatic or manual download of power and energy data from the field instrument with automatic saving into the internal data base (Access® PostgreSQL® or MySQL®).
- Data export to other DBs by means of built-in ODBC or in txt format.

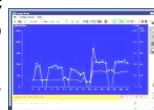

Time-of-use tariffs

- Handling of time of use tariffs
- Built in editor for TOU tariff & Calendar set up.

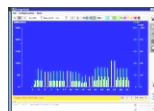

Virtual channels

- Creation of virtual channels (e.g. "summation" of departments, channel "combinations", etc.). Data display and treatment likewise a physical channel.
- Merging of variables and complex mathematical formulas particularly useful, example, for carrying out simulations.

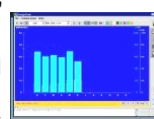

Other types of Energy/Parameter

- Creation of special graphics with data from commercial pulse output transducers (e.g. light, temperature, gas, etc.).

SPECIFIC FUNCTIONS FOR X3M INSTRUMENTS

- Download, storage to PC and display of the events and logs collected by the X3M instruments (all types).
- Set up of events and discrimination in terms of duration (trigger-on value and trigger-off value, number of cycles).

Description	Value
Voltage Dip/Sag & Undervoltage Threshold (V)	30
Voltage Dip/Sag & Undervoltage Restore Threshold (%)	40
Voltage Dip/Sag Max Duration (Cycles)	70
Voltage Swell & Overvoltage Threshold (V)	260
Voltage Swell & Overvoltage Restore Threshold (%)	250
Voltage Swell Max Duration (Cycles)	70
Current Peak & Overcurrent Threshold (A/100)	2500
Current Peak & Overcurrent Restore Threshold (A/100)	2000
Current Peak Max Duration (Cycles)	70

On-line graphs

- Graphs supported for instruments type X3M D6 equipped with FFT harmonics option or for X3M D6 H. Available only with on-line connected Instrument(s).

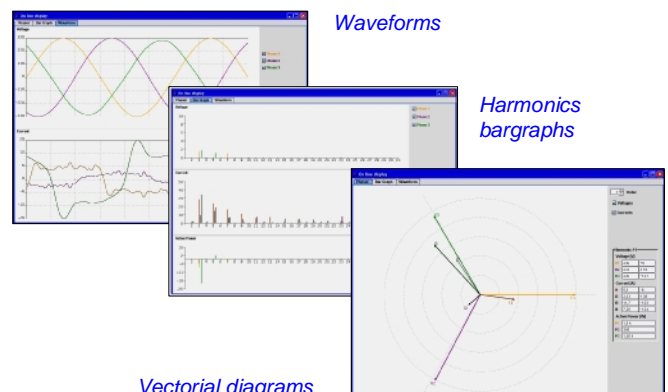

Harmonics/other parameters Survey

- A date/time stamped sample of 42 default readings is automatically saved to the instruments' built-in memory on a circular buffer (FIFO) covering a 10-day survey period with samples taken every 2 minutes.
- On request it is possible to customize the meter(s) to survey other parameters (e.g. Active Power, Power Factor, etc.) even modifying the sample's frequency.

Several Energy Brain software versions are available to meet user requirements and number of channels required. Information available separately.

Technical specification

Readings

Voltage $U_{1-N}, U_{2-N}, U_{3-N}, U_{1-2}, U_{2-3}, U_{3-1}, U_{LL\Sigma}, U_{LN\Sigma}$
 Current $I_1, I_2, I_3, I_{\Sigma}, I_{neutral}$
 Power factor $PF_1, PF_2, PF_3, PF_{\Sigma}$
 Frequency f
 Life time Hours, hours/100
 Voltage THD..... $THD-U_1, THD-U_2, THD-U_3, THD-U_{\Sigma}$
 Current THD $THD-I_1, THD-I_2, THD-I_3, THD-I_{\Sigma}$
 Instantaneous powers . $P_1, P_2, P_3, P_{\Sigma} - Q_1, Q_2, Q_3, Q_{\Sigma} - S_1, S_2, S_3, S_{\Sigma}$
 Average powers..... $Pm\Sigma, Qm\Sigma(ind), Qm\Sigma(cap), Sm\Sigma (imp/exp)$
 $Pm\Sigma, Qm\Sigma(ind), Qm\Sigma(cap), Sm\Sigma (imp/exp)$
 Max. powers (MD).. $Pmd\Sigma, Qmd\Sigma(ind), Qmd\Sigma(cap), Smd\Sigma (imp/exp)$
 Active Energy $E_a (import/export)$
 Reactive energy $E_r (ind), E_r (cap) (import/export)$
 Apparent energy $E_s (import/export)$
 Harmonics (FFT) (*) only for X3M with FFT harm. option or X3M-H
 (*) $H_{U1}, H_{U2}, H_{U3} (1-31^{st} \text{ order})$
 (*) $H_{I1}, H_{I2}, H_{I3} (1-31^{st} \text{ order})$
 (*) Harmonics power & direction (1-31st order)
 Power quality (events logging to built-in memory)
 Voltage sags/dips
 Temporary over-voltage/swell
 Temporary current peak and direction of flow
 Undervoltage/voltage interruption
 Over-voltage
 Over current and direction of flow
 Functional and operational logs

Electrical characteristics

Connection 3-phase, single- & bi-phase, LT and HT grids
 balanced, unbalanced, 3- and 4-wire
 Voltage inputs Direct from 20 to 500V phase-phase
 (max. 1,7 crest factor)
 Via external VTs with max. 400 kV primary rating
 programmable VT values
 Overload max. 900 Vrms peak for 1 sec.
 Current inputs via 1, 2 or 3 external CTs
 max. 10kA primary; .../1A and ..5A secondary
 programmable CT values
 Overload max. 100Arms peak for 1 sec.
 Input burden < 0,5 VA
 Mains frequency 45, 65 Hz
 Power supply 85, 265 Vac/100, 374 Vdc
 or 15, 40 Vac/18-60 Vdc
 (separate from the measurement inputs)
 Self consumption 5 VA

Front panel

Display LCD, STN type, 256 segment
 Display size..... 63 x 65 mm.
 Backlighting white led
 Keyboard 9 keys with explicit function recall
 Calibration Led Available on front panel

How to order

Type	P.N.
X3M 96 85÷265V	PFE 411-00
X3M 96 15÷40V	PFE 411-04
X3M 96 H 85÷265V	PFE 418-00
X3M 96 H 15÷40V	PFE 418-04
Option module 96 RS485	PFE 420-00
Option module 96 RS232	PFE 421-00
Option module 96 2AO4-20mA	PFE 422-00
Option module 96 2DI 2RO	PFE 425-00
Opzione FFT Armoniche (1)	PFSW 399-00

(1) The S.No. of the instrument to upgrade must be indicated when ordering

Functional characteristics

Measurement True-RMS up to the 31st harmonic
 Quadrants 2 and 4 quadrant measurement (programmable)
 Accuracy Class 1 on energy complying with IEC EN 61036.
 Sampling Continuous sampling of current and voltage waveforms
 Compensation Automatic compensation of the amplifiers offsets
 Scale change Automatic scale change on current inputs (2 scales)
 Isolation Galvanic isolation on all inputs and outputs
 Standards
 - Safety: IEC EN 61010 class 2
 - E.M.C.: IEC EN 61326-1A
 - Accuracy: EC EN 61036
 Outputs:
 2 digital outputs rated 27Vdc-27mA (DIN43864)
 with programmable functionality (pulse output or alarm)
 Options ...2 ports for the connection of external expansion modules
 - RS485 communication port
 - RS232 communication port
 - Dual analogue output 4-20 mA
 - Two digital inputs and two relay outputs

Data memory

2 MB flash disc with 20 years data retention
 Data organised in record files with date-time stamping of creation and of last modification.
 Access to the disc by means of the Modbus "Write General File" and "Read General File" commands.
 Real time calendar clock with battery buffer (20 years duration).

Mechanical and environmental

Working temperature range. -20/+60 °C
 Humidity 95% R.H. non condensing
 Enclosure Self-extinguishing plastic material class V0
 Protection degree IP51 (front panel), IP20 (terminals side)
 Size 96 x 96 x 90 mm. (110 mm. with options)
 Mount flush mount
 Panel cut 92 x 92 mm
 Terminals plug-in type with screw protection
 suitable for cables up to 4 mm².
 Weight approx. 410 gr. net

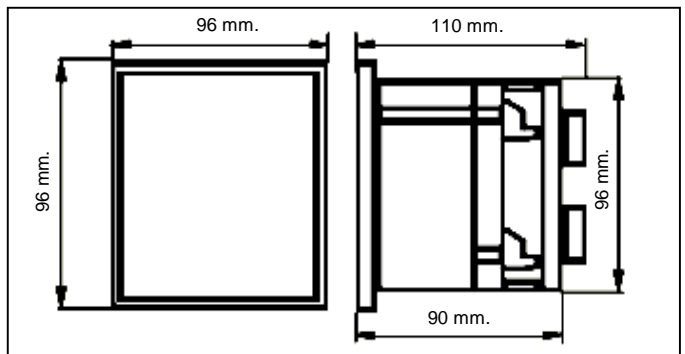

X3M 96 and X3M 96 H are also available in DIN rail format. Please refer to X3M D6 and X3M D6 H data sheet.





Electrex is a trademark of Akse srl
Via Aldo Moro, 39 - 42100 Reggio Emilia (RE) - ITALY
Tel : +39 0522 924244 - Fax : +39 0522 924245
www.electrex.it - email: info@electrex.it

Your distributor

